

## User Manual

Correlator

## Correlux C-3



### Mess- und Ortungstechnik Measuring and Locating Technologies

Elektrizitätsnetze  
Power Networks



Kommunikationsnetze  
Communication Networks



Rohrleitungsnetze  
Water Networks



Abwassernetze  
Sewer Systems



Leitungsortung  
Line Locating





### Consultation with SebaKMT

The present system manual has been designed as an operating guide and for reference. It is meant to answer your questions and solve your problems in as fast and easy a way as possible. Please start with referring to this manual should any trouble occur.

In doing so, make use of the table of contents and read the relevant paragraph with great attention. Furthermore, check all terminals and connections of the instruments involved.

Should any question remain unanswered or should you need the help of an authorized service station, please contact:

<b>Seba Dynatronic</b> <b>Mess- und Ortungstechnik GmbH</b>	<b>Hagenuk KMT</b> <b>Kabelmesstechnik GmbH</b>
Dr.-Herbert-lann-Str. 6 D - 96148 Baunach Phone: +49 / 9544 / 68 – 0 Fax: +49 / 9544 / 22 73	Röderaue 41 D - 01471 Radeburg / Dresden Phone: +49 / 35208 / 84 – 0 Fax: +49 / 35208 / 84 249
E-Mail: <a href="mailto:sales@sebakmt.com">sales@sebakmt.com</a> <a href="http://www.sebakmt.com">http://www.sebakmt.com</a>	

© SebaKMT

All rights reserved. No part of this handbook may be copied by photographic or other means unless SebaKMT have before-hand declared their consent in writing. The content of this handbook is subject to change without notice. SebaKMT cannot be made liable for technical or printing errors or shortcomings of this handbook. SebaKMT also disclaims all responsibility for damage resulting directly or indirectly from the delivery, supply, or use of this matter.

## Terms of Warranty

SebaKMT accept responsibility for a claim under warranty brought forward by a customer for a product sold by SebaKMT under the terms stated below.

SebaKMT warrant that at the time of delivery SebaKMT products are free from manufacturing or material defects which might considerably reduce their value or usability. This warranty does not apply to faults in the software supplied. During the period of warranty, SebaKMT agree to repair faulty parts or replace them with new parts or parts as new (with the same usability and life as new parts) according to their choice.

This warranty does not cover wear parts, lamps, fuses, batteries and accumulators.

SebaKMT reject all further claims under warranty, in particular those from consequential damage. Each component and product replaced in accordance with this warranty becomes the property of SebaKMT.

All warranty claims versus SebaKMT are hereby limited to a period of 12 months from the date of delivery. Each component supplied by SebaKMT within the context of warranty will also be covered by this warranty for the remaining period of time but for 90 days at least.

Each measure to remedy a claim under warranty shall exclusively be carried out by SebaKMT or an authorized service station.

This warranty does not apply to any fault or damage caused by exposing a product to conditions not in accordance with this specification, by storing, transporting, or using it improperly, or having it serviced or installed by a workshop not authorized by SebaKMT. All responsibility is disclaimed for damage due to wear, will of God, or connection to foreign components.

For damage resulting from a violation of their duty to repair or re-supply items, SebaKMT can be made liable only in case of severe negligence or intention. Any liability for slight negligence is disclaimed.

Since some states do not allow the exclusion or limitation of an implied warranty or of consequential damage, the limitations of liability described above perhaps may not apply to you.



**Contents**

**Consultation with SebaKMT .....3**

**Terms of Warranty .....4**

**1 Safety Instructions .....9**

1.1 General Safety Instructions and Warnings.....9

1.2 General Notes .....9

**2 Frequently used menus .....11**

2.1 Start menu .....11

2.2 Pipe data menu .....13

2.3 Correlation menu .....15

2.4 Correlation menu (Offline correlation) .....17

2.5 Correlation analysis menu .....19

2.6 Frequency analysis menu .....21

2.7 Audio menu .....23

2.8 Audio menu (when ground microphone is connected).....25

**3 Technical description .....27**

3.1 Function .....27

3.2 Features of the set .....28

3.3 Communication of the components .....29

3.4 Power supply .....29

3.5 Scope of delivery .....30

3.6 Technical data .....31

**4 The Power transmitters .....33**

4.1 Function and Design .....33

4.2 Identification number (ID).....35

4.3 Power supply .....35

4.4 Commissioning .....36

4.5 Installation .....36

**5 The Multi sensors .....37**

5.1 Design and function.....37

5.2 Identification number (ID).....37

5.3 Power supply .....38

5.4 Switching ON/OFF .....38

5.5 Installation .....39

5.6 Angle adapter .....39

**6 The Correlator .....41**

6.1 Design and function of the device .....41

6.2	Power supply .....	43
6.3	Design of the user interface .....	44
6.4	Basics of operation .....	45
6.4.1	Input methods.....	45
6.4.2	Entering identification numbers.....	45
6.4.3	Entering text .....	46
6.4.4	Sorting devices in lists and tables .....	47
6.4.5	ESC pushbutton and "Back" button .....	47
6.5	Commissioning.....	48
6.5.1	Switch the Correlator ON/OFF .....	48
6.5.2	Basic settings at initial start-up.....	48
6.5.3	Change the language.....	49
6.5.4	Activate the display light.....	49
6.5.5	Enable/Disable the touch screen (touch sensitivity) .....	50
6.6	System settings .....	51
6.6.1	Basic settings .....	51
6.6.2	System info.....	53
6.6.3	Saving the settings .....	53
6.7	Communication .....	54
6.7.1	Connection between the Correlator and the sensors.....	54
6.7.2	Connection between the Correlator and the computer .....	54
6.8	Hardware reset.....	54
<b>7</b>	<b>Sensor management .....</b>	<b>55</b>
7.1	Introduction.....	55
7.2	Access the sensor pool .....	55
7.3	Register sensors .....	57
7.4	Replace / Delete sensors .....	58
7.5	Additional functions .....	59
<b>8</b>	<b>Online correlation.....</b>	<b>61</b>
8.1	Measurement with 2 Power transmitters.....	61
8.2	Measurement with only 1 Power transmitter .....	65
8.3	How to exchange A - B on the screen.....	67
<b>9</b>	<b>Offline correlation (Multipoint measurement) .....</b>	<b>69</b>
<b>10</b>	<b>GPS position data .....</b>	<b>77</b>
10.1	Introduction.....	77
10.2	Determine and save GPS coordinates.....	77
10.3	Distance measurement and navigation via GPS .....	79
<b>11</b>	<b>Real-time measurement.....</b>	<b>81</b>
<b>12</b>	<b>Sound velocity measurement .....</b>	<b>85</b>
12.1	Velocity measurement in Online measurement mode .....	85

- 12.2 Velocity measurement in Offline measurement mode .....88
- 12.2.1 Introduction.....88
- 12.2.2 Procedure .....89
- 12.2.3 Notes and examples.....91
- 13 Map function .....93**
- 14 Storage / Management of correlations (History) .....97**
- 14.1 Storing a correlation .....97
- 14.2 Managing stored correlations .....98
- 14.2.1 Call up and display a correlation .....98
- 14.2.2 Rename a correlation / Create a comment .....99
- 15 Reset of correlation settings and data .....101**
- 16 Pinpointing.....103**
- 16.1 Introduction.....103
- 16.2 Pinpointing using the ground microphone.....103
- 16.3 Pinpointing using Multi sensors.....107
- 17 Query the status of a device .....111**
- 18 Firmware update.....113**
- 18.1 How to update the Correlator .....113
- 18.2 How to update Power transmitters or Multi sensors .....115
- 18.2.1 Work step 1: Download and store the update-file .....115
- 18.2.2 Work step 2: Transfer and run the update-file.....116
- 19 CorreluxView Software .....121**
- 19.1 User interface .....121
- 19.2 Basic settings .....123
- 19.2.1 Storage location for application database .....123
- 19.2.2 GPS receiver port .....123
- 19.2.3 System of units .....123
- 19.2.4 Logarithmic/linear display.....124
- 19.3 Creating, renaming and deleting directories .....124
- 19.4 Importing data .....125
- 19.5 Editing a map .....125
- 19.6 Correlation .....127
- 19.6.1 Perform / display correlation.....127
- 19.6.2 Display / select audio blocks (Offline measurements only).....128
- 19.6.3 Calling up the correlation analysis menu .....129
- 19.6.4 Selecting correlation method (Offline measurements only) .....130



# 1 Safety Instructions

## 1.1 General Safety Instructions and Warnings

	<ul style="list-style-type: none"> <li>• Do not drop the device / the system's components or subject it / them to strong impacts or mechanical shocks.</li> <li>• The limits described under Technical Data may not be exceeded.</li> <li>• The device / system must be in a technically perfect condition for measurement.</li> <li>• The indicated degree of protection can only be ensured if plugs or the provided protection caps are put in all sockets of the device.</li> <li>• The plugs of the supplied connection cables are only compliant to the indicated degree of protection as long as they are plugged in. Plugs which are not connected or which are connected in a wrong way are not protected from water and dust ingress.</li> <li>• If the O-ring seal of a socket is obviously damaged, it must be replaced in order to ensure the total protection against water and dust ingress.</li> </ul>
--	--

## 1.2 General Notes

**Safety precautions** This manual contains basic instructions for the commissioning and operation of the device / system. For this reason, it is important to ensure that the manual is always available to the authorised and trained operator. He needs to read the manual thoroughly. The manufacturer is not liable for damage to material or humans due to non-observance of the instructions and safety advices provided by this manual.

Locally applying regulations have to be observed!

**Labelling of safety instructions** The following signal words and symbols are used in this manual and on the product itself:

Signal word / symbol	Description
<b>CAUTION</b>	Indicates a potential hazard which may result in moderate or minor injury if not avoided.
<b>NOTICE</b>	Indicates a potential hazard which may result in material damage if not avoided.
	Serves to highlight warnings and safety instructions. As a warning label on the product it is used to draw attention to potential hazards which have to be avoided by reading the manual.
	Serves to highlight important information and useful tips on the operation of the device/system. Failure to observe may lead to unusable measurement results.

**Check contents** Check the contents of the package for completeness and visible damage right after receipt. In the case of visible damage, the device must under no circumstances be taken into operation. If something is missing or damaged, please contact your local sales representative.

**Working with products from SebaKMT** It is important to observe the generally applicable regulations of the country in which the device will be operated, as well as the current national accident prevention regulations and internal company directives (work, operating and safety regulations).

Use genuine accessories to ensure system safety and reliable operation. The use of other parts is not permitted and invalidates the warranty.

*Repair and maintenance* Repair and maintenance work has to be carried out by SebaKMT or authorised service partners using original spare parts only. SebaKMT recommends having the system tested and maintained at a SebaKMT service centre once a year.

SebaKMT also offers its customers on-site service. Please contact your service centre if needed.

*Special transportation requirements* The lithium batteries of the device are dangerous goods. The transport of the batteries themselves and of devices which contain such batteries is subject to regulations based on the UN Model Regulations "Transport of Dangerous Goods" (ST/SG/AC.10-1).

Please inform yourself about the transportation requirements and follow them when shipping the device.

*Electromagnetic radiation* This device is designed for industrial use. When used at home it could cause interference to other equipment, such as the radio or television.







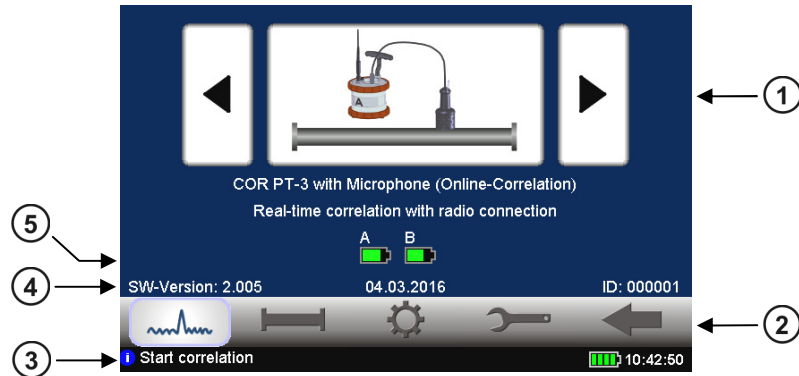

The interference level from the line complies with the limit curve B (living area), the radiation level complies with the limit curve A (industrial area) according to EN 55011. Given that living areas are sufficiently far away from the planned area of operation (industrial area), equipment in living areas will not be impaired.

## 2 Frequently used menus

### 2.1 Start menu

The Start menu appears on the screen after the device has been switched on. In addition, the **ESC** pushbutton takes you back directly to the Start menu from every menu level.



Element	Description
①	<p><b>Measuring mode selection</b></p> <p>Arrow buttons ... To go forward / backward through the available measuring methods.</p> <p>Large central button ... Opens the relevant measuring mode menu or starts the correlation.</p>
②	<p><b>Main menu</b></p> <ul style="list-style-type: none"> <li> Starts the <b>Correlation</b></li> <li> Opens the <b>Pipe data menu</b></li> <li> Opens the <b>Tools menu</b></li> <li> Opens the <b>System settings menu</b></li> <li> Goes <b>Back</b> to the previous menu</li> </ul>
③	<p><b>Info line</b></p> <p>This line provides <b>information</b> on the display, comments and notes on how to proceed. On the right, the <b>Correlator's battery status</b> and the <b>time</b> are shown.</p> <ul style="list-style-type: none"> <li> this symbol indicates info texts</li> <li> this symbol indicates warnings</li> <li> this symbol indicates that an Offline measurement is in progress</li> <li> shows the Correlator battery level</li> </ul>
④	Firmware version / Date / Identification number (ID) of the device

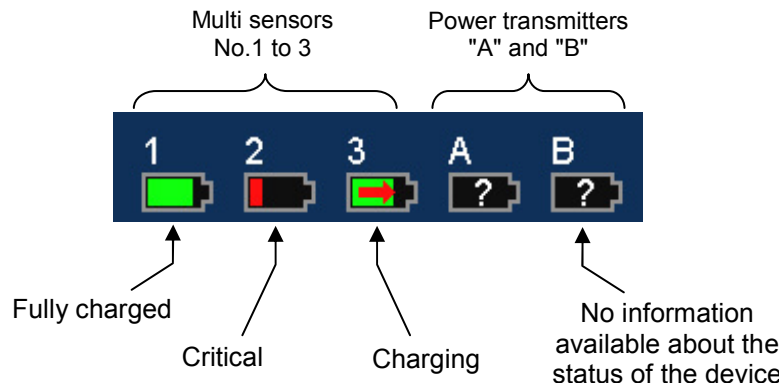

Element	Description
<p>⑤</p>	<p>Battery level of the received Power transmitters or Multi sensors.</p> <div style="text-align: center; margin-top: 20px;">  <p>The diagram illustrates the battery status for five devices. It is divided into two groups: 'Multi sensors No.1 to 3' and 'Power transmitters "A" and "B"'. Each device is represented by a battery icon with a specific color and status:</p> <ul style="list-style-type: none"> <li><b>1</b> (Multi sensor): Fully charged (green battery icon). Label: Fully charged.</li> <li><b>2</b> (Multi sensor): Critical (red battery icon). Label: Critical.</li> <li><b>3</b> (Multi sensor): Charging (green battery icon with a red arrow). Label: Charging.</li> <li><b>A</b> (Power transmitter): No information available (black battery icon with a question mark). Label: No information available about the status of the device.</li> <li><b>B</b> (Power transmitter): No information available (black battery icon with a question mark). Label: No information available about the status of the device.</li> </ul> </div>



## 2.2 Pipe data menu

In the Pipe data menu the properties of the pipe can be specified.

The menu can be opened by:

- tapping the button  in the main menu
- tapping the button between the two diagrams in the Correlation menu, representing the pipe (see next section: button )



**Drop down lists**

- Material** ... Select the pipe section's material.
- Diameter** ... Select the pipe section's diameter.

**Input fields**

- Velocity** ... Input field for the pipe section's sound velocity. The displayed value automatically adjusts to the selected pipe material. The value can be entered manually when needed as well. To do so, tap the field. A numeric keypad opens.

- Length** ... Input field for the pipe section's length. Tap the field. A numeric keypad opens.

**Buttons**

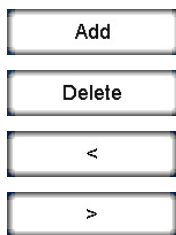

Use these buttons to divide the pipe line displayed in up to 12 sections.

Use these buttons to move from one pipe section to the next.

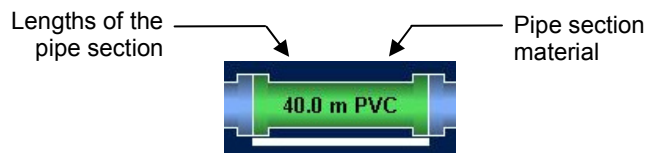

The selected pipe section is "highlighted" with a white bar. The pipe parameters in the four input fields refer to this section.



### 2.3 Correlation menu

After starting a correlation the result is displayed in the following view:

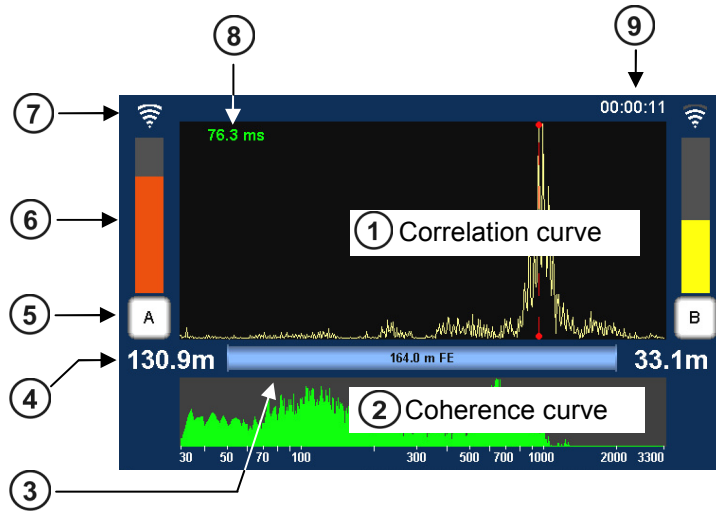

Element	Description
①	<p><b>Correlation curve</b>                      Result from comparing the recordings of the two sensors with regard to the delay time of the signals.                      Tap to open the Correlation analysis menu which provides a number of analysis tools.</p>
②	<p><b>Coherence curve</b>                      Result from comparing the recordings of the two sensors with regard to the frequency range of the recordings.                      Tap to open the frequency filter settings menu.</p>
③	<p><b>Pipeline between A and B</b>                      The graphic illustrates the pipeline between the measuring points A and B with all its sections.                      Tap to open the Pipe data menu.</p>
④	<p><b>Distance from the measuring point to the leak</b></p>
⑤	<p><b>Measuring point A / B</b>                      Indicates whether the Power transmitter A or B is installed at this measuring point.                      Tap the button to open the Audio menu which can be used to listen to the leak noise.</p>
⑥	<p><b>Noise level at the measuring point</b>                      The height of the bar reflects the noise level at the measuring point.</p>
⑦	<p><b>Quality of the radio link between transmitter and Correlator</b></p>

(continued on next page)

Element	Description
<p>⑧</p>	<p><b>Lag value</b>            Indicates the delay of the leak noise between the two sensors. The color of the numbers shows how reliable the result of this correlation is:</p> <p><b>green</b> ... "good" correlation, reliable result  <b>yellow</b> ... correlation is not optimal  <b>red</b> ... "bad" correlation; no leak or unreliable result  <b>negat. sign</b> ... The leak is on the left from the center of the line.  <b>posit. sign</b> ... The leak is on the right from the center of the line.</p>
<p>⑨</p>	<p><b>Term of the correlation</b>            Specifies how long the displayed correlation is already running.            Any interruption resets the counter to 00:00:00.</p>

## 2.4 Correlation menu (Offline correlation)

In Offline measurement mode with Multi sensors, the Correlation menu differs in the following aspects from the menu in Online measurement mode.

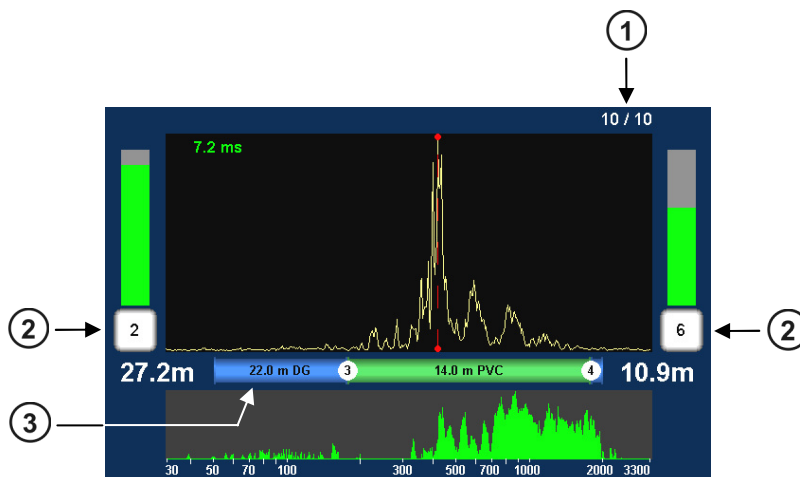

Element	Description
①	<p><b>Number of correlated audio blocks</b></p> <p>The displayed curve is the result of an averaging from up to 10 single correlations.</p>
②	<p><b>Number of the sensor at the measuring point</b></p>
③	<p><b>Pipeline between the measuring points</b></p> <p>The graphic illustrates the pipeline between the measuring points. Tap to open the Pipe data menu.</p> <div style="text-align: center;"> <p>Installation points of sensors No.3 and 4</p> <p>Pipeline sections</p> </div>



## 2.5 Correlation analysis menu

Tapping the **Correlation curve** always opens the following menu. This provides tools for analyzing the correlation.

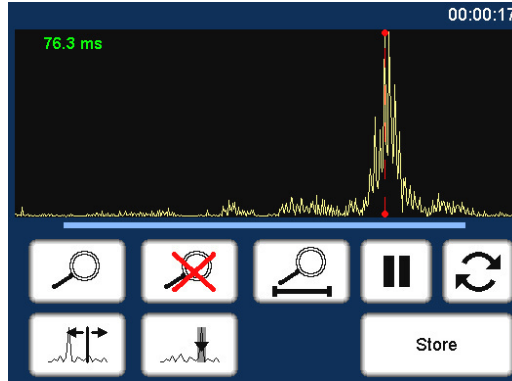

**Zoom ...** to magnify a section of the curve  
Tap the button, then mark the area to be magnified in the diagram.



**Zoom-Reset ...** to reset the curve to its initial state  
Magnification and suppression are abolished. The entire correlation curve is displayed.



**Zoom opt. ...** magnifies length of the pipeline  
Exactly the part of the correlation curve is shown, which refers to the pipe between the two measuring points.

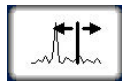

**Move cursor ...** to read the lag value or the distance to the leak at any point of the curve  
Tap the button, then move the vertical red line in the diagram.

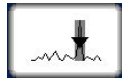

**Suppress ...** to hide a section of the curve  
Tap the button, then mark the area to be suppressed in the diagram, i.e. tap and draw out the required range.



**Suppress individual audio blocks** (only Offline correlation)  
Opens a menu showing the 10 single correlations of this pair of sensors. "Bad" single-correlations can be 'deactivated' and, by this means, excluded from the total-correlation.  
Tap the buttons to remove/set the checkmark. Use the arrow button to return back to the correlation analysis menu.



**Pause**  
Interrupts the current correlation.



**Continue**  
Continues the interrupted correlation, but does not reset the averaging interval.



**Refresh**  
Resets the averaging interval and restarts the correlation.



**Store**  
Opens the Correlation management menu to store the displayed correlation data in the Correlator's data base.





## 2.6 Frequency analysis menu

Tapping the **Coherence curve** always opens the following menu. This provides tools for analyzing the frequency range.

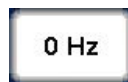
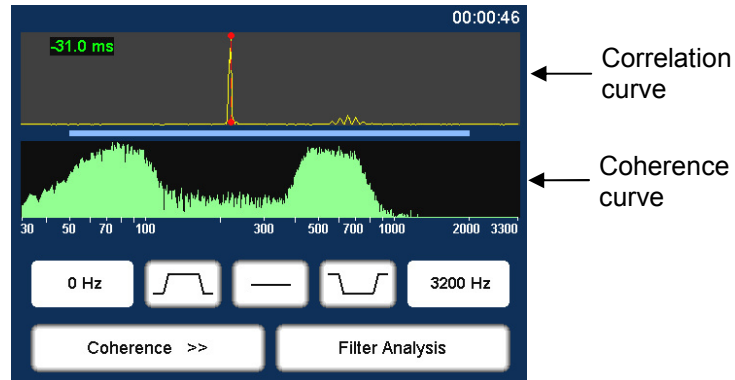

### Lower frequency limit

Shows the lower limit of the frequency range.  
Tap the button to change the value.

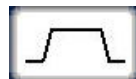

### Bandpass ... to isolate a frequency range

Tap button. Then mark the required range in the frequency diagram.  
The correlation is updated. The frequencies outside the selected range are suppressed.



### Filter reset

Tap the button to reset the frequency filter settings to the initial state.



### Bandstop ... to suppress a frequency range

Tap button. Then mark the required range in the frequency diagram.  
The correlation is updated. The selected frequency range is suppressed.



### Upper frequency limit

Shows the upper limit of the frequency range.  
Tap the button to change the value.

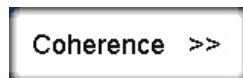

### Frequency spectrum

Allows to change between the following frequency diagram options:

- Coherence ... Coherence of the recordings of both sensors.
- Spectrum L ... Frequency spectrum of the sensor on the left.
- Spectrum R ... Frequency spectrum of the sensor on the right.
- Spectrum L+R ... Frequency spectra of both sensors.
  - Orange curve ... Sensor A
  - Yellow curve ... Sensor B

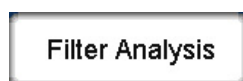

### Automatic search for filter

Provides 10 possible filter settings for selection



## 2.7 Audio menu

Tapping the buttons **A / B / Sensor number** in the Correlation menu opens the Audio menu. It is used to listen to the leak noise via the supplied headphones.

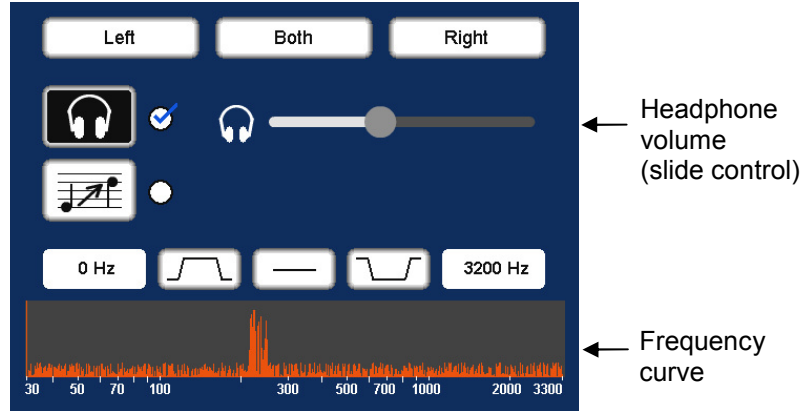

### Listen only to the left sensor

Only the noise recorded by the sensor on the left is reproduced.



### Listen to both sensors

The combined noise of both sensors is reproduced.



### Listen only to the right sensor

Only the noise recorded by the sensor on the right is reproduced.



### Headphones ON / OFF

Button to enable/disable the connected headphones



### Pitching function ON / OFF

This function lifts very low frequencies artificially up to a higher frequency range to make them more audible to the user.

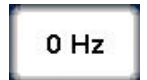

### Audio filter: Lower limit

Shows the lower limit of the frequency range. Tap the button to change the value.



### Audio filter: Bandpass

Specify the frequency range to be reproduced. Frequencies outside this range are suppressed.



### Audio filter: Reset

Tap the button to reset the audio filter settings to the initial state.



### Audio filter: Bandstop

Specify the frequency range to be suppressed, i.e. frequencies in this range are suppressed.

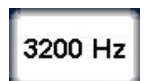

### Audio filter: Upper limit

Shows the upper limit of the frequency range. Tap the button to change the value.



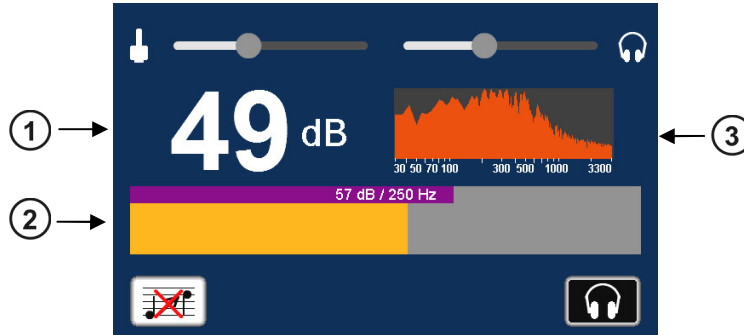

## 2.8 Audio menu (when ground microphone is connected)

A ground microphone can be connected to the Correlator. When you open the Pinpointing function, at first this audio menu appears. It is used to listen to the leak noise via the supplied headphones.

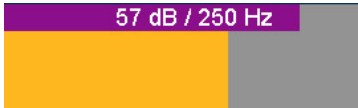
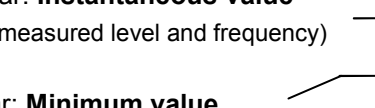

*Indicators*

Element	Description
①	<b>Minimum value</b> lowest noise level of the measurement as a numeric value in dB
②	<b>Bar graph display</b>  Narrow bar: <b>Instantaneous value</b> (currently measured level and frequency) →   Broad bar: <b>Minimum value</b> (lowest level and frequency of measurement) →   The bar's height represents the noise level. The bar's color illustrates the frequency of the noise.  
③	<b>Frequency spectrum</b> Tap to open the menu for adjusting the frequency filter.

*Buttons*



**Headphones ON / OFF**

Button to enable/disable the connected headphones



**Pitching function ON / OFF**

This function lifts very low frequencies artificially up to a higher frequency range to make them more audible to the user.

*Slide controls*



**Microphone gain**

slide to the left ... reduces the gain  
 slide to the right ... increases the gain



**Headphone volume**

slide to the left ... lower  
 slide to the right ... louder



### 3 Technical description

#### 3.1 Function

The Correlux C-3 is a digital Correlator to locate leaks in drinking water pipes.

Pressurized water at the leak location creates a noise which travels out in all directions of the pipe. This noise is recorded, amplified and sent wirelessly to the Correlator by two sensors (piezo microphone, hydrophone) which are attached to the pipe (e.g. valve, hydrants).

The Correlux C-3 compares both signals (correlation) and calculates the exact distance to the leakage on the basis of the delay time of the signals, the sensor spacing and the sound velocity in the pipe.

The Correlux C-3 is suitable for both immediate measurement ("Online measurement") as well as time-delayed measurement ("Offline measurement").

##### Online measurement

In a so-called Online measurement, the noise recording and the correlation of the data take place at the same time.

Step	Description
1	Installing the Power transmitters "A" and "B" at two measuring points.
2	Noise recording, at the same time data transfer and live data correlation on the Correlator.

##### Offline measurement

In a so-called Offline measurement, the correlation of the measured data takes place only after the noise recording has been terminated.

Step	Description
1	Programming the sensors (Multi sensors and Power transmitters)
2	Installing the Power transmitters and/or Multi sensors at up to 8 measuring points.
3	Noise recording, immediately or at a preset time (e.g. at night).
4	Collecting the sensors.
5	Reading and analyzing the measured data using the Correlator.

##### Pinpointing

To determine the exact location of the leak after the correlation, a pinpoint search can be performed using the Multi sensors or the ground microphone connected to the Correlator.

### 3.2 Features of the set

The Correlux C-3 set mainly comprises the following components:

- **Correlator**
- **2 Power transmitters with microphone (Transmitter A / Transmitter B)**  
for recording the leak noise at two measuring points and sending the recorded data to the Correlator



The set can be extended by the following components:

- **up to 8 multi sensors**  
for recording the leak noise of up to 8 measuring points at the same time followed by an "Offline-correlation"
- **hydrophones**  
for recording the leak noise directly at the water column
- **a ground microphone**  
for pinpointing the leak after correlation

The **Transport case** offers space for the Correlator, 2 Power transmitters and 3 Multi sensors. The case is not only for storage and transportation purposes, but also functions as a charging station for the devices.

Using the **CorreluxView** analysis software measurement data can be displayed and processed on the computer. The software can be downloaded from the SebaKMT Internet page:

*[www.sebakmt.com](http://www.sebakmt.com) >> Information > User area > Software > Leak localization*



### 3.3 Communication of the components

The components of the system communicate with each other in the following ways:

Participating devices	Communication channel
Correlator ↔ Power transmitter	Short range radio (digital or analogue)
Correlator ↔ Multi sensors	Short range radio (digital)
Correlator ↔ Computer	USB cable
Correlator ↔ Ground microphone	Connection cable

### 3.4 Power supply

The Correlator, the Power transmitters and the Multi sensors come with internal rechargeable Li-Ion batteries.

The storage places of the individual devices in the transport case function as charging stations. As soon as a device is placed in/on its station in the case, the device is automatically charged, provided the case is connected to the mains.

The case can be connected via the connection socket and the supplied connection cable to either a 12 V connector of a vehicle or to the mains

	<p><b>NOTE</b></p> <p><b>When connected to the electrical system of a car, the transport case is powered by the vehicle's battery, even while the vehicle is not in operation. This could result in the complete discharge of the vehicle battery.</b></p> <p>When you park the car, disconnect the Correlux transport case from the vehicle power supply.</p>
--	--

You can find more information in the chapters which describe the individual devices.

### 3.5 Scope of delivery

*Standard accessory* The basic set comprises the following devices and accessories:

Accessory	Description	Art.no.
COR C-3	Correlator	1006550
COR PT-3A	Power transmitter A	1004779
COR PT-3B	Power transmitter B	1004780
PAM CORR-2	2 x active universal microphone for PT-3	820019615
CPK 3-B	Case for COR C-3 (Basis)	2007235
LG C-3	Charging unit for CPK 3/CMK 3	1006646
LK 13	Car charging adaptor, 3.5m	810000006
KR 22-5	Stereo headphones	810002087
VST T-1	2 x extension rod for PAM CORR-2	810000103
VK 77	Connection cable set Sebalog D (USB)	820012451
	2 x nylon cord 3mm blue, 2m	304035025
CSW CorreluxView C-3	PC software	1006584

*Additional accessory* The following devices and accessories are available to extend the basic set.

Accessory	Description	Art.no.
COR MS-3	Multi sensor	1004815
CMK 3-8-MS	Case for 8 Multi sensors COR MS-3	2005301
LOG TP	Trivet adaptor for Sebalog Corr	128309877
LOG MWA	Magnetic angled adaptor	118303355
	Mounting set for COR MWA (Screws for angled adapters)	2007393
	Set of labels COR C-3 (1 - 8)	2007321

*PAM W-2 ground microphone set* The PAM W-2 ground microphone set is available to extend the basic set. It consists of the following parts:

Part	Description	Art.no.
PAM W-2	Windproof ground microphone	820013157
PAM W-2 D	Trivet adapter for PAM W-2	820013234
VK 65	Connection cable	820000936
	Carrying rod	210100071
VK 100	Connection cable	118302742
Article number of the complete set:		128310702

### 3.6 Technical data

Correlux C-3 is specified by the following parameters:

<i>Correlator COR C-3</i>	<b>Parameter</b>	<b>Value</b>
	Indicators	5,7" VGA color display 640 x 480 pixels
	Entry	Touch display, Rotary encoder with enter function
	Power supply	Internal rechargeable Li-Ion battery, 12 V DC charging pins
	Operating time	min. 16 h
	PC interface	USB
	Connections	Sensor (microphone/hydrophone), 12 V DC / headphones (combined) USB / GPS (combined) External antenna 1 (digital radio) External antenna 2 (analogue radio)
	Dimensions	250 x 190 x 100 mm
	Weight	1.9 kg
	Degree of protection	IP 65

<i>Power transmitter COR PT-3A/B</i>	<b>Parameter</b>	<b>Value</b>
	Sensor	Piezo sensor with active amplifier (standard) / hydrophone (optional)
	Indicators	I/O LED (device On/Off) Radio LED (radio module On/Off) Row of LEDs (battery status or measured noise level)
	Operation	On/Off pushbutton
	Power supply	Internal rechargeable Li-Ion battery, inductive charging
	Operating time	min. 12 h
	Connections	Sensor (microphone/hydrophone), Radio antenna
	Dimensions (without handle)	Ø 125 x 111 mm
	Weight (without sensor)	0.9 kg
	Degree of protection	IP 65

*Sensor  
PAM CORR-2*

<b>Parameter</b>	<b>Value</b>
Type	Piezo sensor with magnetic adaptor (to be connected to Power transmitter or Correlator)
Active amplification	yes
Dimensions	Ø 38 x 78 mm
Weight	0.4 kg
Degree of protection	IP 68

*Ground microphone  
PAM W-2*

<b>Parameter</b>	<b>Value</b>
Type	Wind shielded piezo sensor (to be connected to Correlator)
Dimensions	Ø 185 x 165 mm
Weight	4 kg

*Multi sensor  
COR MS-3*

<b>Parameter</b>	<b>Value</b>
Sensor	Integrated piezo sensor with active amplifier
Adapter	Magnetic adaptor
Indicators	Status LED
Operation	On/Off magnetic switch
Power supply	Internal rechargeable Li-Ion battery, inductive charging
Operating time	min. 16 h
Dimensions	Ø 45 x 115 mm
Weight	0.4 kg
Degree of protection	IP 68

## 4 The Power transmitters

### 4.1 Function and Design

Each Power transmitter has an active amplifier for the microphone signal, a data memory, a rechargeable Li-Ion battery, a digital radio module and an analogue radio module with antenna inside.

The sensors have the following external characteristics:

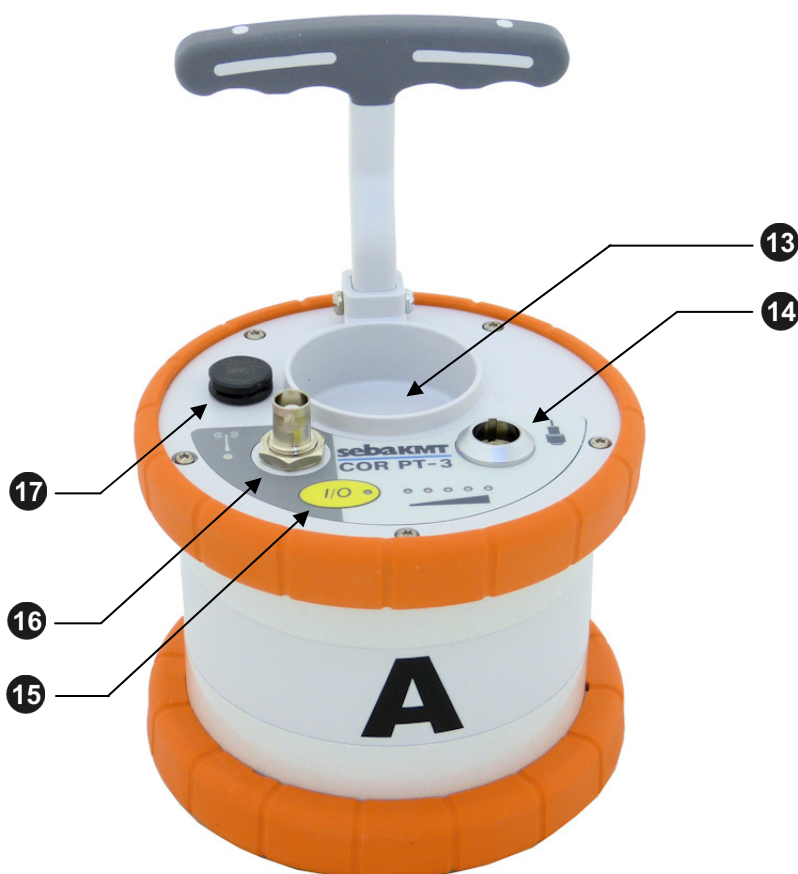

Element	Description
13	<b>Microphone storage place</b>
14	<b>Sensor socket</b> for connecting the microphone / hydrophone
15	<b>I/O pushbutton</b> short pressing ... switches the device on long pressing ... Switches the device off
16	<b>Antenna socket</b> Antenna socket for connecting the analogue radio antenna
17	<b>Ventilation/venting membrane</b>

*Indicator lights* The Power transmitters have the following lights (LEDs):



Element	Description
18	<b>LED bar</b> lit green ... represents the current battery level lit red ... represents the noise level
19	<b>I/O LED</b> lit green ... the transmitter is switched on flashing ... the device is charging not lit ... the transmitter is switched off
20	<b>Radio LED</b> lit red ... the transmitter is in "Active" mode, noise measurement in progress, measurement data is being sent to the Correlator not lit ... the transmitter is in "Stand-by" mode, no measurement in progress, no radio traffic

### 4.2 Identification number (ID)

Each Power transmitter has its own six-digit identification number (short: ID). Using this ID the device can be managed and clearly identified in the Correlator, computer and within the SebaKMT-Cloud.

The ID is deduced from the last six digits of the device's serial number (short: SN). You find the serial number on the nameplate of the device.

When entering an ID on the Correlator or computer, the preceding zero digits can be omitted.

### 4.3 Power supply

*Battery level* The Power transmitters are fitted with internal rechargeable Li-Ion batteries This can power the device for approximately 12 hours.

In the Start menu of the Correlator two battery icons indicate the current battery status of the Power transmitters.

On the Power transmitters, the current battery status is indicated by the LED bar **18** when it is green. If only one of five LEDs is lit, the device should be charged. Otherwise, it switches itself off automatically.

Red light represents the recorded noise during the measurement and not the battery status.

*Charging* The Power transmitters are charged wirelessly in the transport case. The case must be connected to a power supply. As soon as the Power transmitters are situated at their storage places in the case, they are recharged inductively.

Charging takes approximately 12 hours. The I/O LED **19** flashes when loading. The LED bar **18** indicates the progress of charging The I/O LED turns back to permanent light as soon as the battery is full.

	<p><b>CAUTION</b></p> <p><b>No objects must be put into empty charging stations.</b></p> <p><b>Risk of fire!</b></p> <p>The charging stations are for transport and charging of the devices only.</p>
--	---

	<p><b>NOTE</b></p> <p><b>Any repairs must be carried out by SebaKMT or an authorized service partner.</b></p> <p>Otherwise, the devices' resistance against water and dirt cannot be guaranteed.</p> <p>Do not open the device yourself. If you have problems with the battery, please contact your SebaKMT service partner.</p>
--	--

## 4.4 Commissioning

*Switching ON/OFF* To turn on, briefly press the I/O pushbutton **15**. The I/O LED is lit green when the device is turned on. To turn the device off, press the button until the LED goes out.

*Stand-by* The microphone's storage place **13** is fitted with a magnetic switch. As a result, the Power transmitter "knows" whether the microphone is currently in use or not.

As long as the microphone rests in its storage place, the Power transmitter remains in "Stand-by" mode. The internal analogue radio module stays off as no measuring data needs to be transferred to the Correlator. This saves battery power.

As soon as the microphone is taken from the storage place, the Power transmitter switches from "Stand-by" to "Active" mode. The radio module is activated. From now on, the recorded data are directly sent to the Correlator. The row of LEDs switches from green to red and represents the recorded noise level.

## 4.5 Installation

The sensors should be installed directly on the pipe but, however, you can also attach them to valve rods or hydrants, for example, or any other position along the pipeline that is easily accessible.

There must be the best possible contact between the sensor foot or the mounted adapter (see below) and the pipe. If need be, clean the contact point thoroughly (preferably with a wire brush).

In some situations it might be helpful to use one of the supplied magnetic angle adapters.



## 5 The Multi sensors

### 5.1 Design and function

Each Multi sensor has a highly sensitive piezo microphone with active amplifier, a data memory, a rechargeable Li-Ion battery and a radio module with antenna inside.

The sensors have the following external characteristics:



Element	Description
22	<b>Status LED</b> flashes green ... Battery OK flashes yellow ... Battery critical flashes red ... Device needs to be re-charged flashes rapidly ... Device is charging no light ... Device is turned off
23	<b>ON/OFF contact area I/O</b>
24	<b>Magnetic foot (detachable)</b>
25	<b>Type plate</b>
26	<b>Carrying ring (detachable)</b>

### 5.2 Identification number (ID)

Each Multi sensor has its own six-digit identification number (short: ID). Using this ID the device in the Correlator and the CorreluxView PC software can be managed and clearly identified.

The ID is deduced from the last six digits of the device's serial number (short: SN). You find the serial number on the nameplate of the device.

When entering an ID on the Correlator or computer, the preceding zero zero digits can be omitted (see page 45).

### 5.3 Power supply

*Battery level* The Multi sensors are fitted with internal rechargeable Li-Ion batteries This can power the device for at least 16 hours.

In the Start menu of the Correlator up to eight battery icons can be seen. They indicate the current battery status of the registered Multi sensors in reach. To know the exact battery state of a Multi sensor, read the unit's configurations menu (see page 111). In the line **battery status** the battery level of the sensor is shown as a percentage.

When the battery level of a Multi sensor falls below a certain threshold, the indicator light of the device will flash red. The device must be charged. Otherwise, it switches itself off automatically.

*Charging* To charge the Power transmitters place them in the transport case. The case must be connected to a power supply. As soon as the sensors are situated at their storage places in the case, they are recharged inductively.

Charging takes approximately 6 hours. The units' indicator lights are rapidly flashing during the charging process. The indicator lights turn to permanent green light as soon as the battery is full.

	<p><b>CAUTION</b>  <b>No objects must be put into empty charging stations.</b>  <b>Risk of fire!</b>                      The charging stations are for transport and charging of the devices only.</p>
---	---

	<p><b>NOTE</b>  <b>Any repairs must be carried out by an authorized service partner.</b>                      Otherwise, the devices' resistance against water and dirt cannot be guaranteed.                      Do not open the Multi sensors yourself. If you have problems with the battery, please contact your SebaKMT service partner.</p>
---	--

### 5.4 Switching ON/OFF

The Multi sensors have an internal magnetic switch.

To turn a Multi sensor on, briefly hold a magnet (e.g. the foot of another Multi sensor) in front of the sensor's I/O area **23**. The device turns on. The indicator light flashes 3 times.

To turn the device off, hold a magnet in front of the I/O area for approximately 2 seconds. The indicator light will flash 2 times before it goes out.

### 5.5 Installation

The Multi sensors should be installed directly on the pipe. However, you can also attach them to valve rods or hydrants, for example, or any other position along the pipeline that is easily accessible. Due to their powerful magnet, the sensors can also be attached horizontally.

There must be the best possible contact between the sensor foot or the mounted adapter (see below) and the pipe. If need be, clean the contact point thoroughly (preferably with a wire brush).

### 5.6 Angle adapter

In some situations, the Multi sensor cannot be attached directly to the desired measurement point due to its size, e.g. in very narrow shafts or similar. In such cases, it can be helpful to use one of the supplied angle adapters.

*Magnetic connection* Thanks to its magnetic foot, the sensor is simply placed on the adapter. Then, the magnetic adapter can be attached to the pipe or fitting etc.

	<p><b>NOTE</b></p> <p>The sensor's type plate and I/O area <b>23</b> must face away from the angle adapter - as can be seen on the picture.</p> <p>Otherwise, the magnet of the angle adapter would turn off the Multi sensor unintentionally.</p>
--	--



*Screw connection* You can screw the angle adapter firmly to the sensor.

This can be useful as the holding strength between the angle adapter and the pipe in general is higher than the holding strength between the angle adapter and the sensor. When collecting the sensors, it may happen that you pull the sensor from the angle without intention. The adapter then remains on the pipe and it could be difficult to remove it.

Unscrew the magnetic foot from the sensor. Take one of the supplied screws from the Correlux C-3 set to screw the angle adapter on the sensor.

Make sure that the sensor's type plate does face away from the angle adapter.





## 6 The Correlator

### 6.1 Design and function of the device

The COR C-3 Correlator is the central control unit for the Correlux C-3 system.

The device has the following control elements and external features:



Element	Description
1	<b>Rotary encoder</b> Turning ... Guides through the buttons and input fields displayed Pressing ... Executes the selected button or enters the input field
2	<b>ESC pushbutton</b> Exits the current menu and returns to the Start menu
3	<b>I/O pushbutton</b> Short pressing ... Switches the device on or activates the back light for the screen Long pressing ... Switches the device off
4	<b>Charging indicator light</b>
5	<b>Charging pins</b> To charge the device wirelessly in the transport case
6	<b>Ventilation/venting membrane</b>
7	<b>Touch screen</b> (the Touch function can be enabled/disabled in the system settings (see page 50))

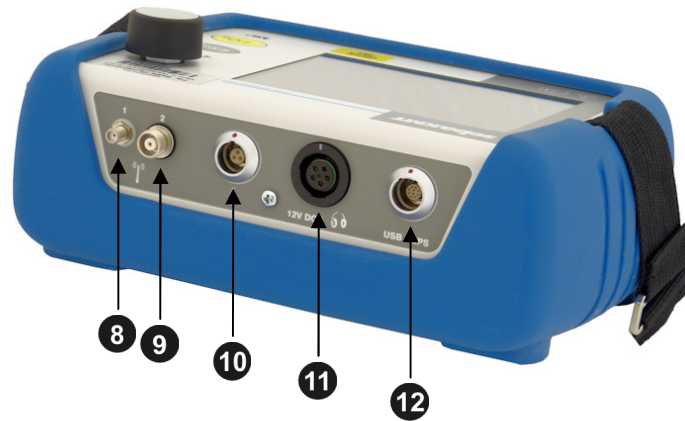

Element	Description
8	<b>Antenna 1 (digital radio)</b> Data transfer in Offline measurement mode
9	<b>Antenna 2 (analogue radio)</b> Measurement data transfer in Online measurement mode
10	<b>Microphone</b> Connection socket for ground microphone
11	<b>12V DC / </b> Connection socket for headphones
12	<b>USB / GPS</b> Combined connection socket for <ul style="list-style-type: none"> <li>• USB cable</li> <li>• GPS receiver</li> </ul>

## 6.2 Power supply

*Internal supply* The Correlator is fitted with an internal rechargeable Li-ion battery. This can power the devices for at least 16 hours. The battery's present charge level is shown by the battery symbol bottom right of the screen.

When the battery is low, a warning tone is heard and a warning message appears on the screen. The device must be charged. Otherwise, it switches itself off automatically.

*Charging* The Correlator is charged wirelessly in the C-3 transport case.

As soon as the device is situated at its storage place in the case, it is recharged via the two pins **5**, provided the case is connected to mains or a 12 Volt vehicle power supply. The red indicator light **4** is lit while the device is charging.

The Correlator is switched on during the entire charging process and can not be deactivated. After the end of charging, the device remains switched on for the Auto-OFF period specified in the system settings before it switches off.

Charging takes approximately 9 hours.

Heat is generated while charging. The charging station in the case therefore has a temperature switch. The charger switches off automatically when it gets too warm inside the case. It turns back on as soon as the degree of heat has fallen below a certain level.



### NOTE

**In order to prevent damage, observe the following precautions when charging:**

- Use only the charging station in the transport case. Do not use other chargers.
- The ambient temperature should be between 10°C and 35°C (50°F and 95°F).
- To avoid heat accumulation, do not close the lid of the case at high ambient temperatures during charging.
- If you experience problems with the battery, please contact your SebaKMT sales or service partner. Do not open the Correlator yourself.

### 6.3 Design of the user interface

All the menu levels on the Correlator's user interface consist of a large **display area**, the **main menu** and an **info bar**.



*Main menu* Using the buttons in the main menu you can access the individual functions of the device.

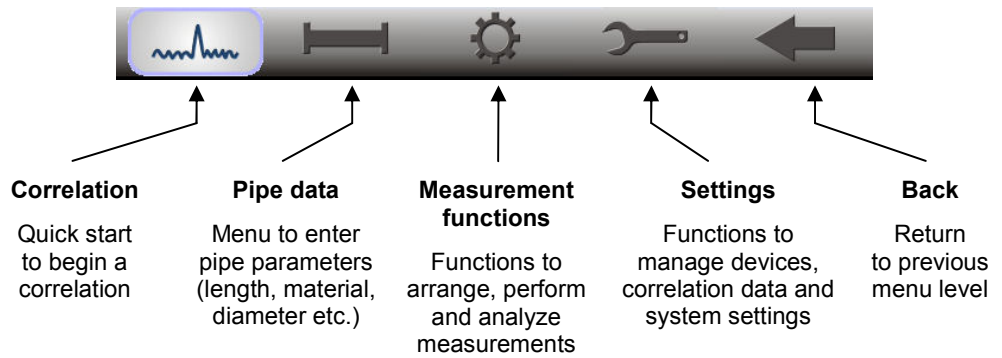

*Info bar* The info bar provides the user with the following information (from left to right):

- A help text with short explanations for the selected element (button / field / box) or on how to proceed
- The battery symbol indicates the charge level of the battery
- The Correlator's internal time



## 6.4 Basics of operation

### 6.4.1 Input methods

Entries can be made directly on the screen or via the rotary encoder.

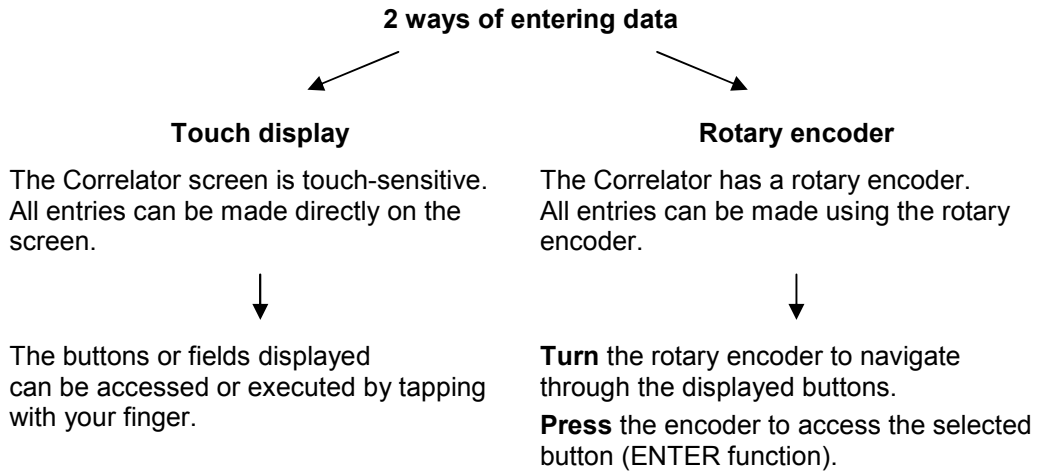

You can always switch between operating via touch screen and operating via rotary encoder.

### 6.4.2 Entering identification numbers

*Introduction* Various functions require the identification numbers (IDs) of the Power transmitters or Multi sensors to be specified.

The ID is deduced from the last six digits of the device's serial number (short: SN). You find the serial number on the nameplate of the relevant device.

**Example:**



Serial number (SN):	<b>0888000225</b>
Identification number (ID):	<b>000225</b>
Entry on Correlator / PC:	<b>225</b>

You can enter device IDs manually or you can use the "Automatic device detection". Automatic detection means that once a device is activated its ID is immediately sent to the Correlator. There, it is detected and displayed.

For entering a device ID the following screen view, or a similar one, opens:

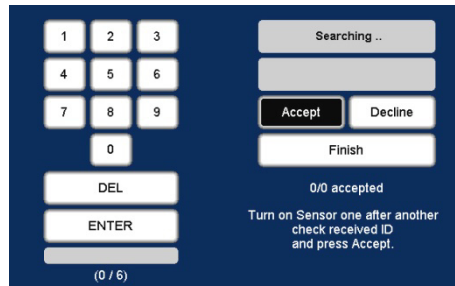

- DEL** ... Deletes the last character
- ENTER** ... Confirms and completes the entry
- Accept** ... Accepts and enters the automatically detected ID
- Decline** ... Does not accept the automatically detected ID
- Finish** ... Completes the automatic detection

*Manual entry* For the manual entry of IDs, use the number pad displayed. Confirm with the ENTER button.

*Automatic detection* To the right of the number pad, there are fields and buttons for the automatic sensor detection. The devices concerned must be close to the Correlator.

To register a Power transmitter, briefly press the I/O pushbutton of the device. To register a Multi sensor, briefly move a magnet past the sensor's I/O area, so that the LED lights up briefly. As a result, the device's ID is sent, detected by the Correlator and displayed on the screen. Using the buttons the detected ID can be accepted or declined. This way several device IDs can be added to the Correlator in quick succession.

### 6.4.3 Entering text

To enter comments or similar, a virtual keyboard appears on the screen. Enter the required text and confirm with **OK**.

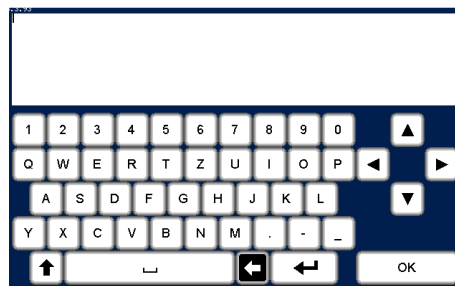

### 6.4.4 Sorting devices in lists and tables

In various menus, device IDs or other information are listed in a kind of table. For example, the following picture shows the Correlator's sensor pool with all registered Multi sensors listed.

Power Transmitter		Multisensors	
Number	▲ Sensor-ID	Sensor type	Used
1	000100	COR MS-3	
2	000101	COR MS-3	
3	000102	COR MS-3	
4	000158	COR MS-3	
5	000104	COR MS-3	
6	000107	COR MS-3	
7	000106	COR MS-3	

If a black triangle can be seen in the header of a column, you have the option to change the sort order (ascending / descending). Just tap the respective header.

Example: In the picture, a triangle can be seen in the **Number** header.

Number ▲	Sensor-ID
1	000140
2	000141
3	000142

Tapping this header changes the sort order of the displayed devices from 1-3 to 3-1.

Number ▼	Sensor-ID
3	000142
2	000141
1	000140

---

---

 Changing the sort order is only possible via touch screen, not via the rotary encoder.

---

---

### 6.4.5 ESC pushbutton and "Back" button

By pressing the **ESC** pushbutton **2** of the Correlator you can cancel or end any process. The button closes the displayed menu and opens the start menu.

You can use the Back button  in the main menu to return to the previous menu level.

**6.5 Commissioning**

**6.5.1 Switch the Correlator ON/OFF**

*Switching ON* The Correlator is switched on with the I/O pushbutton **3**. The device requires a few seconds to boot. Then the Start menu appears on the screen. The device is now ready.



*Switching OFF* To switch the Correlator off, press the I/O pushbutton until the screen turns off (approx. 2 seconds).

*Auto-OFF* The Correlator automatically switches off if no entry is made within a specified time period. This timespan can be configured in the system settings (see page 51).

**6.5.2 Basic settings at initial start-up**

When the Correlator is switched on for the first time, two consecutive Welcome menus appear on the screen. There, some basic system settings have to be made before the Start menu can be entered.

*Language, date and time* Select your language in the first of the two menus. Use the first pull down list to do so. The Correlator's operating language immediately adapts to your selection. After that, enter the remaining requested details.

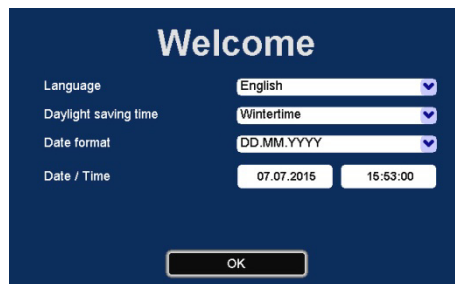

Line	Description
<b>Daylight saving time</b>	Select whether it is currently winter or summer time.
<b>Date format</b>	Select the date format to be used by the Correlator. DD ... Day MM ... Month YYYY ... Year
<b>Date / Time</b>	Enter the current date and time (hour:minute:second) for the Correlator.

Confirm with **OK**. The menu is closed. The settings are accepted.

You have the option to change these settings again in the Correlator's system settings menu, at any time.

*Devices of your set* Specify in the next menu which devices are part of your Correlux C-3 set. Tick the relevant checkbox/es.



The statements made here determine which measuring methods will be offered in the Correlator's Start screen.

Example: If you select no checkbox except "COR PT-3", the Online measurement method "COR PT-3 with microphone" will be the only available method in the Start screen.

Confirm with **OK**. The menu is closed. The settings are accepted. The Start menu of the Correlator appears.

You have the option to change these settings again in the Correlator's system settings menu, at any time.

### 6.5.3 Change the language

The operating language can be changed in the system settings of the device.

If currently a foreign language is set, call the Start menu and follow these symbols:



Next to the second flag you find a pull-down list with all available languages.

### 6.5.4 Activate the display light

The display light is switched on once

- the screen is touched (provided the touch function is not disabled)
- the rotary encoder is turned
- the I/O pushbutton is briefly pressed

The light remains on for a certain time period. The length of this period can be adjusted in the system settings.

### 6.5.5 Enable/Disable the touch screen (touch sensitivity)

The touch function of the screen can be disabled/enabled if needed. The screen will no longer respond to tapping. The device can only be operated using the rotary encoder.

*Enable/disable touch function* To enable/disable the touch function, proceed as follows:

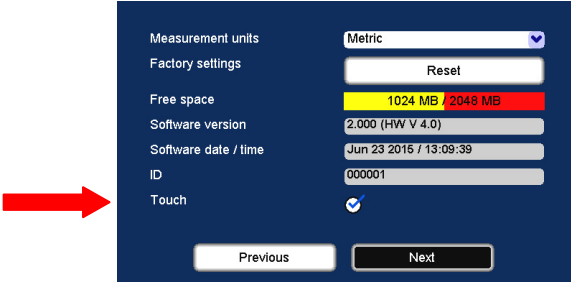
Step	Description
1	In the main menu, select the button  .
2	In the displayed menu, select the <b>System settings</b> button. <b>Result:</b> The system settings menu is opened. Use the buttons <b>Next</b> and <b>Previous</b> to browse through the available settlings.
3	Look for the <b>Touch</b> option. Enable/Disable the corresponding checkbox. 

## 6.6 System settings

By means of the **System settings** various device settings can be customized to the needs of the user. Furthermore, the menu provides useful information on the status of the device and the firmware used.

To access the **System settings** menu, proceed as follows:

Step	Description
1	In the main menu, tap the button  .
2	In the displayed menu, tap the <b>System settings</b> button.  <b>Result:</b> The system settings menu is opened. Use the buttons <b>Next</b> and <b>Previous</b> to browse through the available settings.

### 6.6.1 Basic settings

The following basic settings can be made

Line	Description
<i>Backlight</i> <b>Backlight switch off</b>	Select a period of time for the backlight until it is switched off automatically. <u>Explanation:</u> If no entry is made, the display light is switched off automatically after a period of time. Specify the length of this period here. If you select <b>never</b> , the backlight will remain on permanently.
<i>Auto-OFF</i> <b>Turn off autom. after</b>	Select a period of time for the Correlator until it is switched off automatically. <u>Explanation:</u> If no entry is made, the device switches itself off automatically after a period of time. Specify the length of this period here. If you select <b>never</b> , the Correlator will remain switched on permanently.
<i>Key beep</i> <b>Key beep</b>	Activate/deactivate the key tone that sounds when a button is tapped or the rotary encoder is pressed.
<i>Language</i> <b>Language</b>	Select your language.

<i>Time and date</i>	<b>Timezone</b>	Select the time zone for where you are.
	<b>Daylight saving time</b>	Select whether it is currently winter or summer time.
	<b>Date format</b>	Select the date format to be used by the Correlator. DD ... Day MM ... Month YYYY ... Year
	<b>Date / Time</b>	Enter the current date and time (hour:minute:second) for the Correlator.
<i>Format of units</i>	<b>Measurement units</b>	Select the system of units to be used by the Correlator. Metric ... Used in Europe and most countries around the world Imperial ... Used in the US
<i>Reset system settings</i>	<b>Factory settings</b>	Tap the <b>Reset</b> button if you want to reset all system settings to factory defaults.
<i>Touch screen ON/OFF</i>	<b>Touch</b>	Enable/Disable the touch function (touch sensitivity) of the screen. If this function is disabled, the screen only works as a display. The device can only be operated using the rotary encoder.
<i>Averaging during correlation</i>	<b>Averaging</b>	Select the averaging interval. <u>Explanation:</u> When performing an Online measurement, the calculation will automatically be restarted and the displayed correlation curve will be updated at regular intervals. Here you set the time interval <b>no averaging</b> ... No averaging takes place. <b>20 s</b> ... Averaging of the correlation curve takes place in a 20 seconds interval. <b>unlimited</b> ... Averaging of the correlation curve takes place with every new received measuring data package.

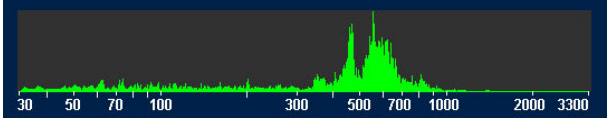
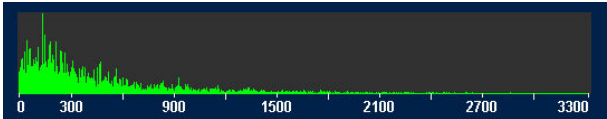

*Frequency scale  
linear / logarithmic*

<b>Frequency scale</b>	<p>Select if the X-axis of the coherence diagram in the Correlation menu shall ascend in a linear or logarithmic way.</p> <p><u>Explanation:</u> The frequency range of the Correlux C-3 system is from 0 to 3300 Hz. Based on experience the frequency of leak noise ranges from 0 to 1000 Hz. The logarithmic view results in a wider display area for lower frequencies.</p> <p>logarithmic:</p>  <p>linear:</p> 
------------------------	--

*Available measuring  
methods  
in Start menu*

<b>Available quick start buttons</b>	<p>Specify which devices are part of your Correlux C-3 set. Enable/Disable the relevant checkbox/es.</p> <p><u>Explanation:</u> The statements made here determine which measuring methods will be offered in the Correlator's Start screen.</p> <p>Example: If you select no checkbox except "COR PT-3", the Online measurement method "COR PT-3 with microphone" will be the only available method on the Start screen.</p>
--------------------------------------	---

### 6.6.2 System info

The **System settings** menu has the following information on the device and the firmware currently in use:

Line	Description
<b>Free space</b>	The Correlator's free memory space in MB
<b>Software Version</b>	Firmware version of the Correlator
<b>Software date/time</b>	Date of the last firmware updates
<b>ID</b>	Identification number of the Correlator

### 6.6.3 Saving the settings

When leaving the system settings menu all the settings are automatically saved and accepted.

**6.7 Communication**

**6.7.1 Connection between the Correlator and the sensors**

Short range radio is used for communication between the Correlator and the sensors (Power transmitters and Multi sensors).

Analogue short range radio is used for Online measurements. Digital short range radio is used for Offline measurements. Therefore, the Correlator is equipped with two radio antennas.

- Antenna 1 ... Digital radio
- Antenna 2 ... Analogue radio

**6.7.2 Connection between the Correlator and the computer**

The included VK 77 connection cable is used to connect the Correlator to a PC/laptop. This connection is needed for

- correlation data transfer to the computer
- firmware update file transfer to the Correlator

*Connecting* To connect the Correlator to a computer, proceed as follows:

Step	Description
1	In the main menu, tap the button  .
2	In the displayed menu, tap the <b>Connect Correlator to PC</b> button.
3	Establish the cable connection. Connect the round plug of the cable to the <b>USB/GPS</b> socket <b>12</b> of the Correlator. Observe the markings on the plug and socket. You must feel the plug engage.
4	Tap the <b>Connect</b> button on the Correlator. <b>Result:</b> The connection is established. The Correlator is automatically detected by the computer as a mass storage device. As soon as the <b>Connected</b> message on the Correlator's screen appears, data can be transferred.

If no connection is made, check the cable connection again. If necessary, disconnect the Correlator from the computer, restart it or perform a reset, and follow steps 1 to 4 once again.

*Disconnecting* To end the connection, select the **Disconnect** button on the Correlator. As soon as the **Disconnected** message appears, the connection cable can be removed.

**6.8 Hardware reset**

If the Correlator stops responding to inputs (neither from touch screen nor from rotary encoder or pushbuttons), a hardware reset can be performed.

Hold down the rotary encoder **1** and the **ESC** pushbutton **2** at the same time for about one second. The Correlator restarts automatically. This usually rectifies the malfunction.

If the device still malfunctions after resetting the device, try the following: Hold down the rotary encoder and the **ESC** pushbutton at the same time for about 3 seconds. The Correlator switches off. Wait about a minute before switching the Correlator back on. The Correlator should now function correctly again.

## 7 Sensor management

### 7.1 Introduction

All Power transmitters and Multi sensors of your Correlux C-3 set have to be registered in the Correlator.

Two Power transmitters and up to 8 Multi sensors can be registered. The units make up the so-called "sensor-pool". The Correlator can only communicate with registered devices.

### 7.2 Access the sensor pool

To access the sensor pool, proceed as follows:

Step	Description
1	In the main menu, tap the button  .
2	In the displayed menu, tap the <b>Sensor management</b> button. <b>Result:</b> One additional menu appears, if the Correlator currently is in Offline measurement mode. There, tap the <b>Edit / Manage</b> button. <b>Result:</b> The Correlator's sensor pool appears.

*Indicators* The sensor pool is divided into two sections:

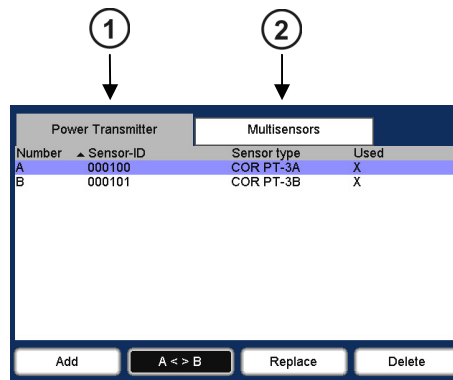

Element	Description
①	<b>"Online" pool</b> Under the <b>Power transmitter</b> tab the two Power transmitters of your set are managed which are used for Online correlations.
②	<b>"Offline" pool</b> Under the <b>Multi sensor</b> tab the Multi sensors and Power transmitters are managed which can be used for Offline correlations.

The registered sensors are listed respectively. The **columns of the table** have the following definitions:

Number	Sensor-ID	Sensor type	Used
A	000120	COR PT-3A	X
B	000121	COR PT-3B	X
1	000140	COR MS-3	
2	000141	COR MS-3	
3	000142	COR MS-3	

Element	Description
①	<b>Index / Number of the device</b> <b>A / B</b> ... indicates whether this is the Power transmitter A or B <b>1 - 8</b> ... shows the number of this Multi sensor which was assigned to the device during the registration
②	<b>Identification number of the device</b>
③	<b>Type designation</b> of the device (as it is also found on the nameplate) <b>COR PT-3A</b> ... Power transmitter "A" <b>COR PT-3B</b> ... Power transmitter "B" <b>COR MS-3</b> ... Multi sensor
④	Sensors which are marked with an <b>X</b> have been used in the last measurement.

### 7.3 Register sensors

*Add sensors for Online measurements* To register a Power transmitter for Online measurements, proceed as follows:

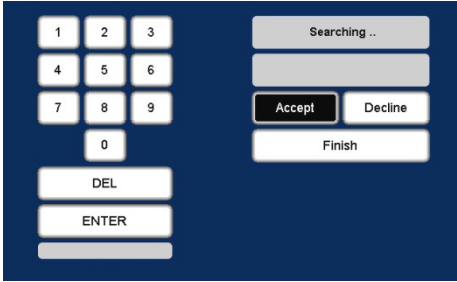
Step	Description
1	In the Sensor pool menu, select the <b>Power transmitter</b> tab.
2	Tap the <b>Add</b> button.  <b>Result:</b> A question appears on the screen. You must decide whether the Power transmitter in question shall be added to the "Online pool" only or to both the "Online pool" and "Offline pool" at the same time.
3	Use the buttons <b>Yes</b> or <b>No</b> to answer the question displayed. <b>No</b> ... The device will only be added to the Online pool. <b>Yes</b> ... The device will be added to both pools at the same time  <b>Result:</b> The menu for entering device IDs opens.  
4	Enter the ID of the Power transmitter.  <div style="display: flex; justify-content: space-between;"> <div style="width: 45%;"> <p><u>Via manual input:</u></p> <ul style="list-style-type: none"> <li>• Enter the ID.</li> <li>• Confirm with the <b>ENTER</b> button.</li> </ul> </div> <div style="width: 45%;"> <p><u>Via „Automatic detection“:</u></p> <ul style="list-style-type: none"> <li>• Briefly contact the I/O field of the Multi sensor with a magnet or press the I/O button of the Power transmitter.</li> <li>• On the Correlator screen, confirm the ID displayed with <b>Accept</b>.</li> <li>• Add another sensor or conclude by tapping <b>Finish</b>.</li> </ul> </div> </div> <p><b>Result:</b> The display returns to the Sensor management menu. The relevant device now appears in the list. If the device could not be added, maybe there already exists a Power transmitter of the same type (PT-A or PT-B) in the list. It is not possible to manage two PT-A or two PT-B in the same list.</p>

*Add sensors for Offline measurements.* For Offline measurements, Multi sensors as well as Power transmitters can be used. Therefore, the Offline pool can contain both types of sensors.

To register a sensor for Offline measurements, proceed as follows:

Step	Description
1	In the Sensor management menu, select the <b>Multi sensor</b> tab.
2	Tap the <b>Add</b> button.  <b>Result:</b> The menu for entering device IDs opens.

(continued on next page)

Step	Description
3	<p>Enter the identification number of the sensor in question.</p> <p><u>Via manual input:</u></p> <ul style="list-style-type: none"> <li>• Enter the ID.</li> <li>• On the right, a drop-down list appears. There, select whether the device in question is a Multi sensor (COR MS-3) or a Power transmitter (COR PT-3).</li> <li>• Confirm with the <b>ENTER</b> button.</li> </ul> <p><u>Via „Automatic detection“:</u></p> <ul style="list-style-type: none"> <li>• Briefly contact the I/O field of the Multi sensor with a magnet or press the I/O button of the Power transmitter.</li> <li>• On the Correlator screen, confirm the ID displayed with <b>Accept</b>.</li> <li>• Add another sensor or conclude with <b>Finish</b>.</li> </ul> <p><b>Result:</b> The display returns to the Sensor management menu. The relevant device now appears in the list.</p> <p>Every Multi sensor receives a consecutive number from 1 to 8, according to the registration order. This number is displayed in the first column of the table. The number will be used in various functions of the Correlator to represent this sensor.</p>

## 7.4 Replace / Delete sensors

*Replace a sensor* You can remove a single sensor from the pool and replace it by a new sensor. Proceed as follows:

Step	Description
1	In the list, tap on the applicable sensor.
2	Tap the <b>Replace</b> button.
3	<p>Answer the question displayed with <b>Yes</b>.</p> <p><b>Result:</b> The menu for entering device IDs opens.</p>
4	<p>Enter the identification number of the sensor which you want to add new to the sensor pool. Use the key pad displayed or the "Automatic detection".</p> <p><b>Result:</b> The display returns to the Sensor management menu. The new sensor now appears in the list. It takes over the number of the replaced sensor.</p>

*Delete a sensor* To remove a sensor from the pool, proceed as follows:

Step	Description
1	In the list, tap on the applicable sensor.
2	Tap the <b>Delete</b> button.
3	<p>Answer the question displayed with <b>Yes</b>.</p> <p><b>Result:</b> The sensor is removed from the list.</p>

### 7.5 Additional functions

*Change sorting order of power transmitters*

Using the **A <> B** button you can reverse the sorting order of the two Power transmitters A and B in the Online pool. This step has an impact on the Correlation menu which is shown on the screen when performing an Online measurement.

Variant 1: Sorting order A → B

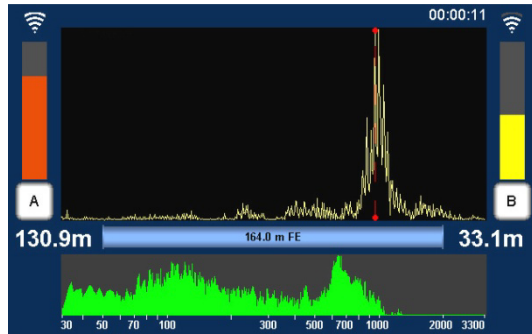

In the Correlation menu, Power transmitter A appears on the left, Transmitter B appears on the right.

Variant 2: Sorting order B → A

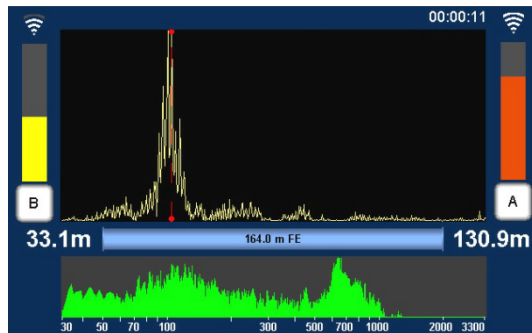

In the Correlation menu, Power transmitter A appears on the right, Transmitter B appears on the left.

*Change a sensor's number*

You can change a Multi sensor's number in the sensor pool. Proceed as follows:

Step	Description
1	In the list, tap on the applicable sensor.
2	Tap the <b>Change number</b> button.
3	Answer the question displayed with <b>Yes</b> . <b>Result:</b> A key pad appears on the screen.
4	Enter the new number for this sensor. A number from 1 to 8 is possible. There must not be two devices with the same number in the sensor pool. Confirm with the <b>ENTER</b> button. <b>Result:</b> The display returns to the sensor pool menu. The relevant sensor is now shown with the new number in the list.





## 8 Online correlation

### 8.1 Measurement with 2 Power transmitters



*Checklist prior to measurement*

The following requirements must be met or preparations must be made:

- The batteries of the Power transmitters and the Correlator must be charged.
- All radio antennas have to be properly connected to the Power transmitters and the Correlator.
- The microphones/hydrophones have to be properly connected to the Transmitters.
- The radio of each Power transmitter should be tested. For this, take the transmitter's microphone from the storage place. The Radio LED **20** must now be lit. If not, put the microphone back to the storage place, switch the transmitter off and on again and repeat the test.

*Start correlation*

Deploy the Power transmitters at the required measuring points and start the correlation. Proceed as follows:

Step	Description
1	Take the Power transmitter "A" (orange) and go to the first measuring point. Attach the microphone to the pipe (or, alternatively, install the hydrophone). Switch the Power transmitter on.
2	Take the Power transmitter "B" (yellow) and go to the first measuring point. Attach the microphone to the pipe (or, alternatively, install the hydrophone). Switch the Power transmitter on.
3	Take the Correlator and choose a position half way between the measuring points. Switch the Correlator on.
4	In the Start menu, use the arrow buttons ◀▶ to choose the required Online measuring mode ( <b>COR PT-3 with microphone</b> or <b>COR PT-3 with hydrophone.</b> )

Step	Description
5	To start the measurement, tap the large central button in the display area or tap the button  in the main menu.
	<b>Result:</b> The correlation starts. The Correlation Analysis menu opens.

*Rate the correlation* Rate the correlations. To do so answer the following questions.

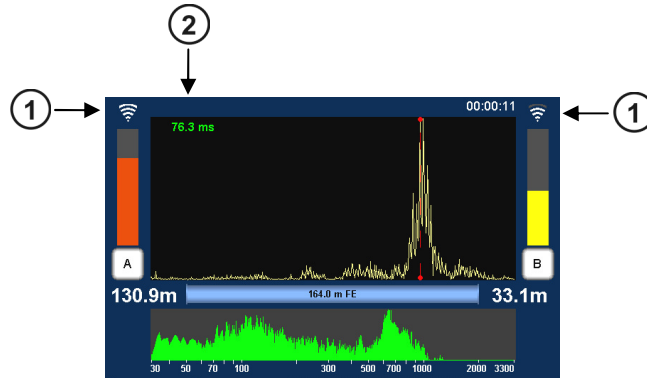

**Is the radio signal of both transmitters strong enough?**



If the radio symbol ① shows a strong signal, the measurement can be continued and a detailed analysis can be started.



If the radio symbol ① shows a weak signal, a continuous correlation will be hardly or not possible.

The following actions may help:

- Move closer to the Power transmitter in question.
- Place the transmitter higher (e.g. on a wall or on a traffic cone or similar).
- If necessary, place the transmitter at an other measuring point.
- If possible, there should be a direct line of sight connection between Correlator and transmitter.

If still no connection can be made, conduct an Offline measurement instead of the Online measurement.

**Is the correlation result reliable?**

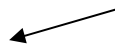

The curve shows one clear peak; the lag value ② is green or yellow and does not fluctuate

Meaning: The result is reasonable.

How to proceed: Continue the measurement and start a detailed analysis.

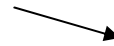

The curve shows no clear peak; the lag value ② is red and fluctuating

How to proceed: If you still suppose a leak to be here, the following can help:



- Access the system settings menu, adjust the „Averaging“ to “unlimited” and restart the correlation.
- Conduct an Offline measurement (at night) instead of the Online measurement.

**Listen to leak noise** You have the option to listen to the sound in the pipe “live”, in order to judge whether a leak noise or a background noise can be heard.

Connect the supplied headphones to the **12 V DC / 3.0** socket of the Correlator. In the Correlation menu, tap the button **A** or **B** to access the Audio menu (see chapter 2).

**Enter pipe parameters** If you assess the correlation as "good", in the next step specify the properties of the pipe in order to be able to calculate the distance to the leak.

Proceed as follows:

Step	Description
1	<p>In the Correlation menu, tap the button between the two diagrams representing the pipe or use the button  in the main menu.</p> <p><b>Result:</b> The Pipe data menu opens.</p> 
2	<p>Reproduce the pipeline. Use the <b>Add</b> and <b>Delete</b> buttons to divide the line into sections.</p>
3	<p>Enter the pipe data (material, diameter, length) for each section.</p>
4	<p>Use the Back button  to return to the Correlation menu or the Start menu. The entered pipe data are accepted</p> <p><b>Result:</b> In the Correlation menu, the distance from transmitter <b>A</b> or <b>B</b> to the leak is displayed now.</p>

*Rate the leak position* Use the following questions to assess whether the leak position seems plausible or not.

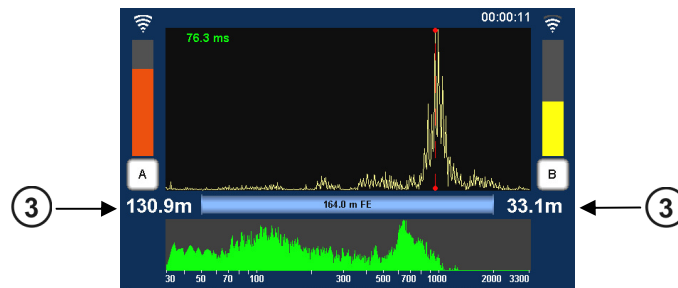

**Is one of the values ③ zero or close to zero?**

If the answer is **NO**, the values seem plausible.

Continue the measurement and start a detailed analysis.

If the answer is **YES**, the leak is located precisely at the measuring point or outside the correlated pipe section.

Cancel the measurement. Take the relevant transmitter and look for a new installation point in order to enlarge the measuring length. Then start a new correlation.

**Does each value ③ show the half of the measuring length**

If the answer is **NO**, the values seem plausible.

Continue the measurement and start a detailed analysis.

If the answer is **YES**, the leak is located precisely half way between the measuring points or a measuring error has occurred (so called 'center point correlation').

Cancel the measurement. Take one of the transmitters and look for a new installation point in order to enlarge the measuring length. Then start a new correlation.

*Detailed analysis* Use the various tools to analyze the displayed correlation:

- When you tap the displayed correlation curve, the **Correlation analysis menu** with the relevant tools opens.
- When you tap the displayed coherence curve, the **Frequency analysis menu** with the relevant tools opens.

Use the Back button  to return to the Correlation menu.

Some settings for calculating and presenting the correlation curve can be changed in the in the System settings menu (see page 51).

## 8.2 Measurement with only 1 Power transmitter

It is possible to replace one of the two Power transmitters by the Correlator. Thus, the Correlator performs both, the function of a control unit and the function of a noise sensor at the second measuring point.

This allows performing Online measurements even if one of the two Power transmitters is not available or malfunctions.

*Connect the microphone* The universal microphone PAM CORR-2 needs to be connected to the Correlator. Simply use the microphone of the not used Power transmitter.

The Correlator's microphone socket has this icon:  Observe the markings on the plug and socket. You must feel the plug engage.

*Configure the Correlator* On the Correlator, it has to be specified which Power transmitter will be replaced at the coming measurement.

Proceed as follows:

Step	Description
1	In the Start menu, use the arrow buttons to choose an Online measuring mode, e.g. "COR PT-3 with microphone".
2	In the main menu, tap the button  .
3	In the displayed menu, tap the <b>Sensor connection</b> button.
4	In the menu displayed, specify which Power transmitter shall be replaced by the Correlator at the next measurement.

Variant 1: The measurement shall be performed without Power transmitter A? Then tap the **Direct** button beneath **A** and confirm with **OK**.

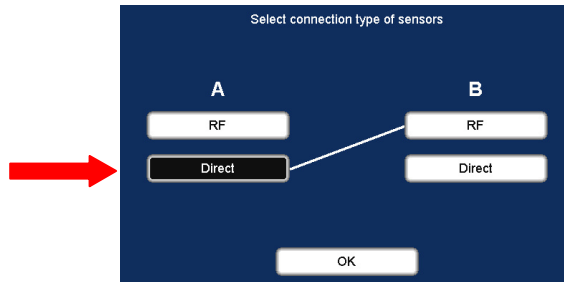

Variant 2: The measurement shall be performed without Power transmitter B? Then tap the **Direct** button beneath **B** and confirm with **OK**.

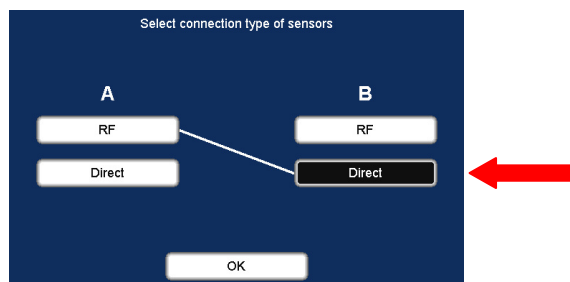

Use the Back button  or the **ESC** pushbutton to return to the Start menu.

The changed setting is accepted and will become effective at the next measurement. The setting will remain valid until it is changed again in the **Sensor connection** menu or until the **Reset last correlation data** command in the System settings menu is used to reset all measurement data (see page 101).

*Perform measurement* First, take the Power transmitter which shall be used, go to the first measuring position. Attach the sensor to the pipe and turn the device on.

Then, take the Correlator and go to the second measuring position. Attach the sensor which is connected to the Correlator to the pipe.

The measurement can now be started using the button  in the main menu.

*Reset the "Sensor connection" setting* Before the next Online measurement with two Power transmitters can be performed, the Sensor connection setting has to be reset.

For this, access the Sensor connection menu and tap the **RF** button beneath **A** as well as the **RF** button beneath **B** and confirm by pressing **OK**.

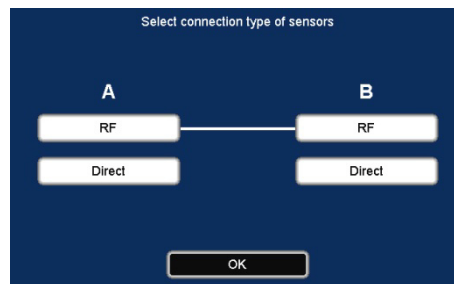

If you use the **Reset last correlation data** command in the System settings menu prior to a new correlation, the Sensor connection setting will be reset to **RF-RF** at the same time.

### 8.3 How to exchange A - B on the screen

In the Correlation menu, the Power transmitter icons **A** and **B** are positioned to the left and right of the correlation curve. As standard, Power transmitter A is on the left, Power transmitter B is on the right.

It is possible to exchange the two icons on the screen, when required. Then, Power transmitter A will be on the right, Power transmitter B will be on the left.

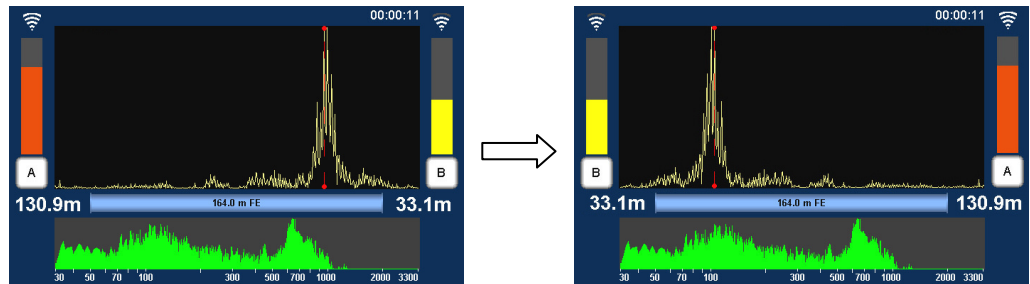

*Procedure* To exchange the Power transmitter icons with each other, proceed as follows.

Step	Description
1	In the main menu, tap the button
2	In the displayed menu, tap the <b>Sensor management</b> button.  <b>Result:</b> The Sensor management menu opens. There, the list of Power transmitters is shown. If this is not the case, tap the <b>Power Transmitter</b> tab.
3	Tap the <b>A &lt; &gt; B</b> button.  <b>Result:</b> The sort order of the two Power transmitters in the list is reversed.

Use the Back button or the **ESC** pushbutton to leave the menu. The changed setting is accepted and will become effective as soon as a new correlation is performed. The setting will remain valid until it is changed again in the same way.





## 9 Offline correlation (Multipoint measurement)

A group of 2 to 8 sensors is programmed for measurement and then deployed at the measuring points. Multi sensors and/or Power transmitters can be used. The measurement is carried out by all sensors simultaneously. During the measurement, there is no contact between the sensors or between the sensors and the Correlator. After the measurement, the sensors are collected and the recorded data is read, then correlations can be carried out and displayed on the Correlator.

*Checklist prior to measurement*





The following requirements must be met or preparations must be made:

- A digital or printed pipe network plan of the relevant measuring area with all pipe parameters is needed.
- The batteries of the devices involved must be charged.
- All sensors involved must be registered in the Correlator's Multisensor pool (also called "Offline pool" (see page 55))
- If Power transmitters will be used: The microphones must be properly connected.
- All sensors must be received by the Correlator. (This is the case, when each battery icon in the Correlator's Start menu shows the battery level of the relevant sensor. If a question mark is shown, the corresponding sensor cannot be reached.)

*Programming sensors* Configure the sensors for the measurement:

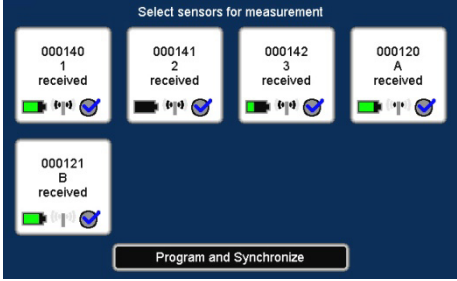
Step	Description
1	All sensors must be turned on.
2	<p>In the Correlator's Start menu, select the required Offline measuring mode ("COR MS-3 with microphone" or "COR MS-3 with hydrophone").</p> <p>Use the arrow buttons to choose the mode, then tap the large central button to open it up.</p> <div style="text-align: center;"> </div>
3	<p>In the displayed menu, tap the <b>Program</b> button.</p> <div style="text-align: center;"> </div>

(continued on next page)

Step	Description		
	<p><b>Result:</b> In the displayed menu, up to 8 fields represent the sensors which are registered in the Correlator's Multi sensor pool.</p> 		
4	<p>Select the sensors which shall be programmed. Tap the appropriate field to enable/disable the checkbox. Only "enabled" sensors will be part of the measurement.</p> 		
5	<p>Tap the <b>Program and Synchronize</b> button.</p>		
6	<p>In the menu displayed, decide whether the measurement shall be carried out immediately or at night. Tap one of the two buttons:</p> <div style="display: flex; justify-content: space-around; align-items: flex-start;"> <div style="text-align: center;">  <p><b>Instantaneous measurement</b> (<u>Explanation:</u> measurement takes 2min 30sec and starts directly after the sensors have been deployed)</p> </div> <div style="text-align: center;">  <p><b>Custom measurement</b> (<u>Explanation:</u> Start and end time of the measurement are set by the user)</p> </div> </div>		
7	<table border="0" style="width: 100%;"> <tr> <td style="width: 50%; vertical-align: top;"> <p>Use the <b>Time offset</b> field to specify the period of time which it will take to deploy the sensors at the individual measuring points. The entered time span will later be used as a "countdown to measurement".</p> </td> <td style="width: 50%; vertical-align: top;"> <p>Use the <b>Start of measurement</b> field to specify when the measurement shall start. Use the <b>End of measurement</b> field to specify when the measurement shall be finished.</p> </td> </tr> </table>	<p>Use the <b>Time offset</b> field to specify the period of time which it will take to deploy the sensors at the individual measuring points. The entered time span will later be used as a "countdown to measurement".</p>	<p>Use the <b>Start of measurement</b> field to specify when the measurement shall start. Use the <b>End of measurement</b> field to specify when the measurement shall be finished.</p>
<p>Use the <b>Time offset</b> field to specify the period of time which it will take to deploy the sensors at the individual measuring points. The entered time span will later be used as a "countdown to measurement".</p>	<p>Use the <b>Start of measurement</b> field to specify when the measurement shall start. Use the <b>End of measurement</b> field to specify when the measurement shall be finished.</p>		
8	<table border="0" style="width: 100%;"> <tr> <td style="width: 50%;">Tap the <b>OK</b> button.</td> <td style="width: 50%;">Tap the <b>OK</b> button.</td> </tr> </table>	Tap the <b>OK</b> button.	Tap the <b>OK</b> button.
Tap the <b>OK</b> button.	Tap the <b>OK</b> button.		
	<p><b>Result:</b> The sensors are programmed and synchronized successively. The Correlator successively establishes a connection to each sensor. The progress of the operation is shown on the screen. When the operation is completed, a countdown appears on the screen showing the time remaining before the measurement starts.</p>		

Deploying sensors

Step	Description	
9	Deploy the sensors at the measuring points.	Deploy the sensors at the measuring points.
	<p><b>Result:</b> Once the countdown reached zero, the sensors start measuring.</p> <p>A new countdown of 2min 30sec is displayed on the Correlator screen representing the total time of the measurement. During this time, the sensors simultaneously record 10 audio blocks, each of 3 seconds length. Once the countdown reached zero, the measurement is completed.</p>	<p><b>Result:</b> The sensors start measuring at the programmed time.</p> <p>A new countdown is displayed on the Correlator screen showing the time remaining until the programmed end of measurement.</p> <p>During this time, the sensors simultaneously record 10 audio blocks, each of 3 seconds length. Once the countdown reached zero, the measurement is completed.</p>
10	<p>Once the measurement is completed, collect the sensors.</p> <p>The sensors need to remain turned on. Otherwise the measurement data would be lost.</p>	

Reading out data To read the measuring data from the sensors, proceed as follows:

Step	Description
1	In the Start menu, select the required Offline measuring mode.
2	<p>In the displayed menu, tap the <b>Read</b> button.</p> <div data-bbox="740 1120 1197 1400" data-label="Diagram"> <p>The diagram illustrates a four-step process: 1. 'Program' shows a handheld device and sensors. 2. 'Read' shows the device communicating with the sensors. 3. 'Correlation' shows a screen with multiple waveform graphs. 4. 'Automatic Correlation' shows a screen with two sensors and a bar chart.</p> </div> <p><b>Result:</b> The Correlator successively contacts all sensors. Thereby, the devices are synchronized. Then, the following menu appears:</p> <div data-bbox="740 1529 1197 1809" data-label="Image"> <p>The screenshot shows a menu titled 'Read recorded audio data'. It lists five sensors: 1 (000140) received, 2 (000141) received, 3 (000142) received, A (000120) received, and B (000121) received. Each entry has a green progress bar and a blue circular icon. At the bottom, there is a 'Read all' button and the instruction 'Press the button for downloading audio data'.</p> </div>

(continued on next page)

Step	Description	
3	If you want to read the audio files of all sensors, tap the <b>Read all</b> button.	If you want to read just one sensor, tap the field of the sensor in question.
<p><b>Result:</b> The audio files are successively transferred. The progress of the operation is shown in the individual fields.</p> <div style="text-align: center;">  </div> <div style="display: flex; justify-content: center; align-items: center; margin-top: 10px;"> <div style="text-align: center;"> <p>← Radio packages received</p> <p>← Audio files received</p> </div> </div>		

Use the **ESC** pushbutton to return to the Start menu.

Perform correlation

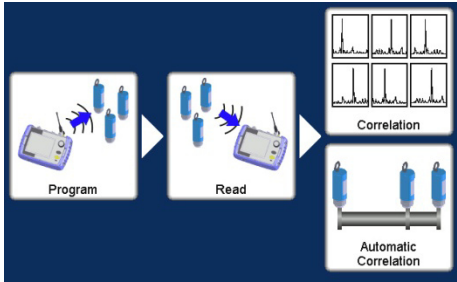
Step	Description
1	In the Start menu, select the required Offline measuring mode.
2	In the displayed menu, tap the <b>Correlation</b> button.  

**Result:** A "Multi correlation" is carried out, which means that the values of all sensors are correlated with each other. The process can take a few seconds. Subsequently, the correlation results for all sensor pairs are shown in thumbnails.

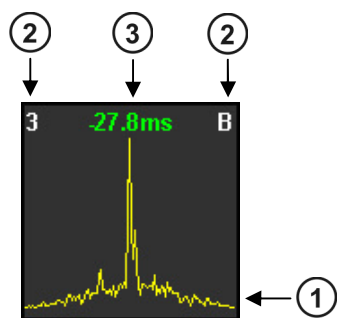

Element	Description
①	Correlation curve
②	Sensor numbers of the two devices whose data are correlated.
③	Time distance from the middle of the pipe line to the leak. The color of the numbers shows how reliable the result of this correlation is: green ... "good" correlation, reliable result yellow ... correlation is not optimal red ... bad correlation; no leak or no clear localization possible negat. value ... the leak is on the left from the center of the line posit. value ... the leak is on the right from the center of the line

*Rate correlations* The Multi correlation gives you an overview of the noise situation along the measured pipeline. In the ideal case, the pipe sections where leaks are most likely can be identified at a glance.

Rate the displayed correlations.

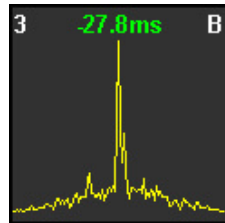

**"Good correlation"**

- clear peak
- lag value is green
- lag value is not zero



Probability of a leak is high

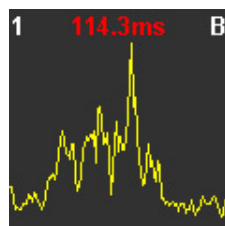

**"Bad correlation"**

- more than one peak
- lag value is yellow or red
- lag value is zero or nearly zero



No leak or no clear localization possible

If the Multi correlation shows at least one "good correlation" with one clear peak, the probability of a leak between the respective sensors is high.

Take a closer look at the good correlations. Tap the relevant thumbnail. The Correlation menu for this sensor pair appears.

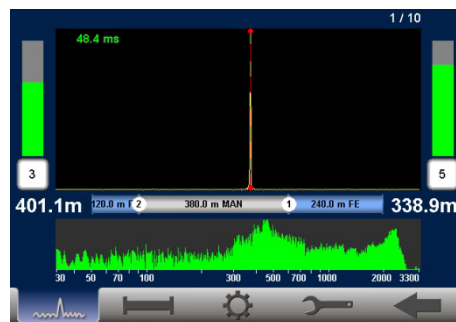

*How to proceed if there is pipe data* To be able to calculate the distance to the leak, the properties of the pipe have to be specified.

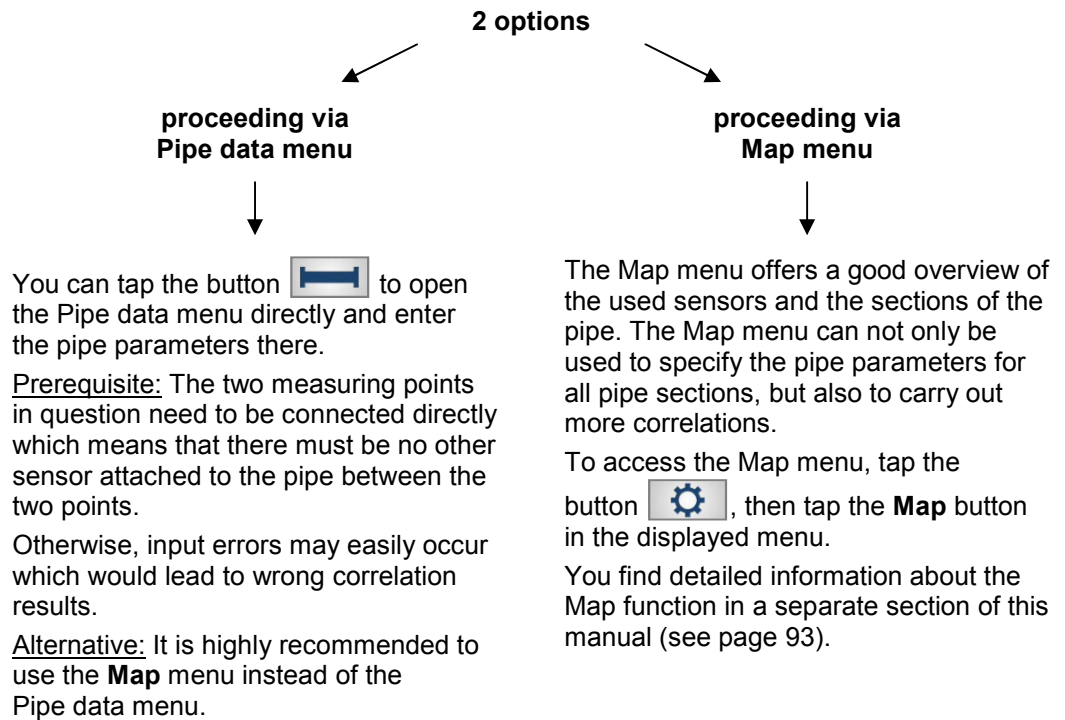

*How to proceed if there is no pipe data available* If there is no complete pipe data available, you have the option to switch now to the **"Velocity measurement"** menu.

This menu is for:

- Calculating the distance between a sensor and the leak, although material and diameter of the pipe are unknown.
- Calculating the sound velocity in the pipe. The value can then be adopted for further correlations.

You find detailed information on how to use the Velocity measurement function in a separate section in this manual (see page 88).





## 10 GPS position data

### 10.1 Introduction

You can use the Correlator to determine and store the GPS coordinates of the individual measuring points.

GPS data facilitate the management and analysis of the measured data in the Offline measurement. For some analysis capabilities GPS data are even a prerequisite.

*Requirements* The GPS receiver **LOG GPS-3** has to be connected to the Correlator. The GPS receiver is optionally available.

The GPS module is connected to Correlator using the **USB / GPS** socket. You must feel the plug engage. The GPS module is powered by the Correlator. The device switches on immediately after connection and is ready for operation. The status LED lights up. The device immediately begins to search for GPS signals.

### 10.2 Determine and save GPS coordinates

To determine the GPS position for a sensor, you must take the Correlator and proceed as close as possible to the installed device.

Subsequently, proceed as follows:

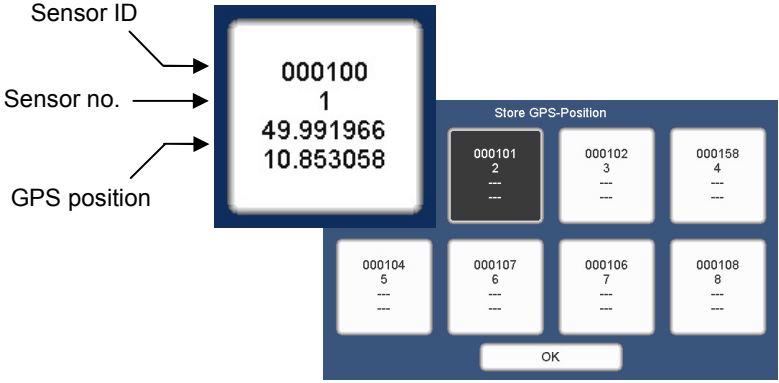
Step	Description
1	In the main menu, tap the button  .
2	<p>In the displayed menu, tap the <b>Store GPS position</b> button.</p> <p><b>Result:</b> The following menu opens. Up to 8 fields represent the sensors which are registered in the Correlator's Multisensor pool.</p> 
3	<p>Tap the field of the sensor whose position is to be determined.</p> <p><b>Result:</b> The GPS menu opens. The GPS receiver is searching for available satellites.</p> <p>After a while, the current GPS time is displayed.</p> <p>As soon as the position of the Correlator can be calculated, the current latitude and longitude are specified.</p>

(continued on next page)

Step	Description
	<div data-bbox="746 309 1201 591" style="text-align: center;"> </div> <p data-bbox="480 622 1350 685">You can change the GPS format for displaying the GPS position. Tap the <b>GPS format</b> button to select one of the following formats:</p> <ul data-bbox="504 694 861 801" style="list-style-type: none"> <li>• Decimal degrees</li> <li>• Degrees, minutes</li> <li>• Degrees, minutes, seconds</li> </ul> <p data-bbox="480 817 1420 880">The bar at the right of the screen indicates how high the accuracy is with which the position can currently be determined.</p>
<p data-bbox="427 898 448 927"><b>4</b></p>	<p data-bbox="480 898 1394 960">Wait until the position has leveled out on a reliable value. The bar to the right should show an accuracy of 100%.</p> <hr/> <div data-bbox="491 992 563 1081" style="float: left; margin-right: 10px;"> </div> <p data-bbox="576 992 1452 1086">The first time the position is determined after connecting the GPS module may take a some time. The Correlator should not be moved during this phase. It is best to put it down somewhere.</p> <hr/>
<p data-bbox="427 1140 448 1169"><b>5</b></p>	<p data-bbox="480 1140 740 1169">Tap the <b>Store</b> button.</p> <p data-bbox="480 1184 1445 1214"><b>Result:</b> The coordinates are accepted. The display returns to the previous menu.</p>

### 10.3 Distance measurement and navigation via GPS

You can use the GPS function of the Correlator to determine the distance between two points. You can also use GPS navigation as a guide to find a stored GPS position.

*Access the menu* To open the GPS menu, proceed as follows:

Step	Description
1	In the main menu, tap the button  .
2	In the displayed menu, tap the <b>Tools</b> button.
3	In the displayed menu, tap the <b>Distance measurement / Navigation</b> button.

The menu is structured as follows:

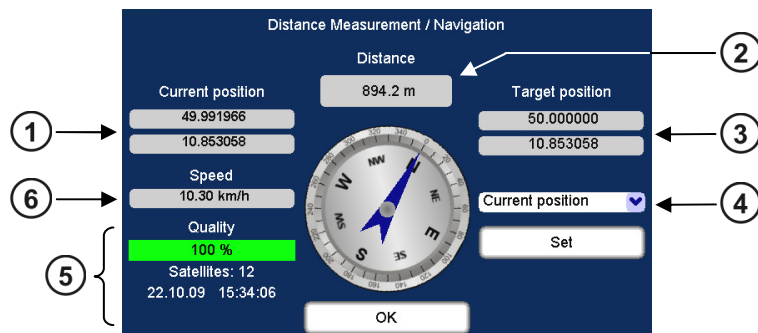

Element	Description
①	<b>Current position</b> Indicates the current position of the Correlator. Once the Correlator is moved, the displayed value is adapted.
②	<b>Distance</b> Indicates the linear distance between the Correlator ① and the Target position ③.
③	<b>Target position</b> Indicates the GPS position of the point, which was defined as Target position.
④	<b>Sensor list</b> List of all sensors, i.e. measuring points, whose GPS coordinates have been determined and stored. One of these sensor installation points can be selected and specified as Target position.
⑤	top down: <ul style="list-style-type: none"> <li>• Positioning accuracy for the Correlator position (in percent).</li> <li>• Number of available GPS satellites.</li> <li>• The current GPS date and GPS time.</li> </ul>
⑥	Speed at which the Correlator is currently moved.

*Distance from here to a measuring point* You can calculate the distance from your current position to a stored measuring point.

In the drop-down list ④, select the sensor which is installed at the relevant measuring point.

The GPS coordinates of the measuring point are adopted and displayed as the new "Target position". The distance information is updated and displays the distance between the Correlator and the measuring point.

*Distance from here to any location* You can calculate the distance from your current position to any other location. Proceed as follows:

Step	Description
1	In the drop-down list ④, select <b>Current position</b> .
2	Tap the <b>Set</b> button. <b>Result:</b> The GPS coordinates of your current location are adopted and displayed as the new "Target position".
3	Take the Correlator and proceed to the desired other location. <b>Result:</b> The distance information is updated and displays the distance from your current to the previous location.

*Navigating to a location* You can use the directional sign of the GPS menu to guide you to a measuring point. Proceed as follows:

Step	Description
1	In the drop-down list ④, select the sensor which is installed at the relevant measuring point. <b>Result:</b> The GPS coordinates of the measuring point are adopted and displayed as the new "Target position".
2	Go into the direction the compass needle shows. The target location is reached when the "Current position" coordinates match the "Target position" coordinates.
	 The direction specified by the compass needle is reliable, as long as you are in motion. Once you stand still at a place, the needle begins to rotate and the direction shown is no longer reliable.

## 11 Real-time measurement

With a single sensor, you can perform a real-time measurement. By this means, you get an idea about the current noise situation in the pipe.

The real-time measurement can be performed with a Power transmitter or with a Multi sensor.

At the desired location, the sensor is attached to the pipe. Then, via the Correlator a noise measurement is started. The measurement data are transferred from the sensor to the Correlator and displayed there in real-time.

If a Power transmitter is used, you have the chance to listen to the recorded noise "live" via headphones.

*Requirements* The following requirements must be met:

- The relevant Power transmitter or Multi sensor must be registered to the Correlator.
- The battery level of the sensor must be OK.  
(Power transmitter: LED bar must show at least 2 green lights  
Multi sensor: status LED must show green or yellow light)
- The measuring point must be in the Correlator's radio range (max. 5 m).
- If a Power transmitter will be used: Antenna and microphone must be properly connected.

*Perform measurement* Switch the Power transmitter or Multi sensor on and attach the sensor to the pipe. Subsequently, proceed as follows:

Step	Description		
1	<table border="0" style="width: 100%;"> <tr> <td style="width: 50%; vertical-align: top;">                     If a Power transmitter is used, use the arrow buttons in the Correlator's Start menu to choose an Online measuring mode (e.g. "COR PT-3 with microphone").                 </td> <td style="width: 50%; vertical-align: top;">                     If a Multi sensor is used, use the arrow buttons in the Correlator's Start menu to choose an Offline measuring mode (e.g. "COR MS-3 with microphone").                 </td> </tr> </table>	If a Power transmitter is used, use the arrow buttons in the Correlator's Start menu to choose an Online measuring mode (e.g. "COR PT-3 with microphone").	If a Multi sensor is used, use the arrow buttons in the Correlator's Start menu to choose an Offline measuring mode (e.g. "COR MS-3 with microphone").
If a Power transmitter is used, use the arrow buttons in the Correlator's Start menu to choose an Online measuring mode (e.g. "COR PT-3 with microphone").	If a Multi sensor is used, use the arrow buttons in the Correlator's Start menu to choose an Offline measuring mode (e.g. "COR MS-3 with microphone").		
2	In the main menu, tap the button  .		
3	In the displayed menu, tap the <b>Tools</b> button.		
4	In the displayed menu, tap the <b>Real time measurement</b> button. <b>Result:</b> A new menu opens. The up to 8 fields displayed represent the Power transmitters or Multi sensors registered in the Correlator's sensor pool.		
5	In the display, tap on the device which you want to use for the measurement. <b>Result:</b> The Real-time measurement menu opens. The measurement is started. The progress of the measurement is shown on the screen.		

Use the **ESC** pushbutton to finish the real-time measurement and to return to the Start menu.

*View measurement results* The course of the real-time measurement is shown on the Correlator's screen with a running bar diagram.

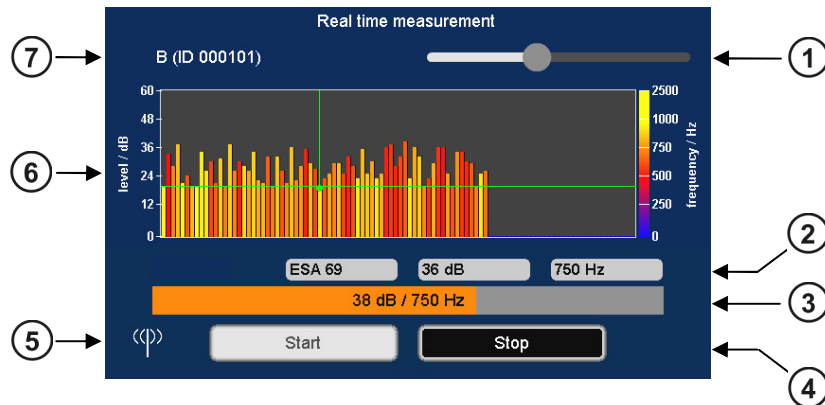

Element	Description
①	<b>Headphone volume</b> slide control slide to the left ... lower slide to the right ... louder
②	<b>Minimum value</b> left-hand field ... ESA value of the quietest recording center field ... noise level of the quietest recording (in dB) right-hand field ... frequency of the quietest recording (in Hz)
③	<b>Instantaneous value</b> noise level (in dB) and frequency (in Hz) of the current measuring value shown as numeric values and as a bar graph bar height ... noise level bar color ... frequency
④	<b>Start and Stop</b> buttons to cancel and continue the measurement
⑤	<b>Antenna symbol</b> indicates that radio communication is in progress
⑥	<b>Diagram</b> X-axis ... course of measurement over time Y-axis ... noise level in dB Each bar represents a single noise recording. The color of the bar shows the approximate frequency of the noise: <div style="text-align: center;"> <span style="color: blue;">blue</span> <span style="display: inline-block; width: 20px; height: 10px; background: linear-gradient(to right, blue, purple, red, orange, yellow);"></span> <span style="color: yellow;">yellow</span>  <span style="margin-right: 100px;">0 Hz</span> <span>3300 Hz</span> </div> The point where the two green lines intersect marks the quietest recording in the displayed measurement.
⑦	<b>Number and ID</b> of the sensor

*Listening to the noise „live“* If a Power transmitter is used, you have the option to listen to the recorded noise "live" via headphones.

Connect the supplied headphones to the **12 V DC / ** socket of the Correlator. Observe the markings on the plug and socket.

The sound is reproduced as long as the measurement is in progress. To adjust the headphone volume use the slide control top right of the screen.

If a Multi sensor is used, listening to the recorded noise is not possible. To save energy, no audio files are transferred from the sensor to the Correlator.





## 12 Sound velocity measurement

The Correlux C-3 system can be used to perform a sound velocity measurement in order to determine the actual speed of sound in a pipe section.

This function is useful when no reliable information on the pipe material is available for a pipe section or the entire measurement area. The calculated sound speed is then accepted by the Correlator and used for the correlation.

The calculation of the speed of sound is possible in both the Online measurement as well as the Offline measurement mode.

### 12.1 Velocity measurement in Online measurement mode

The **Velocity measurement** function compares the measuring values of the Power transmitters while they are recording the noise from one specific source. The sound velocity in the pipe is calculated using the sound delay.

There must be a source of noise on the pipe, which is clearly measurable for both sensors. If such a noise source does not exist, it must be created artificially, for example, by opening a fire hydrant.

*Requirements* The following conditions must be met in order to use the function:

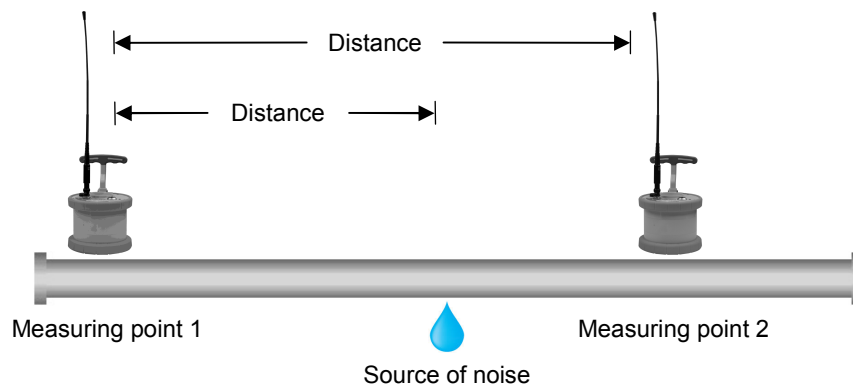

- Two Power transmitters (PT-A and PT-B) at two measuring points.
- The distance between the measuring points must be known.
- The noise must be clearly measurable for both sensors.
- The source of noise may be inside or outside the measuring section.
- The source of noise should not be half way between the measuring points.
- If the source of noise is inside the measuring section, the distance from the first measuring point to the sound source must be known.

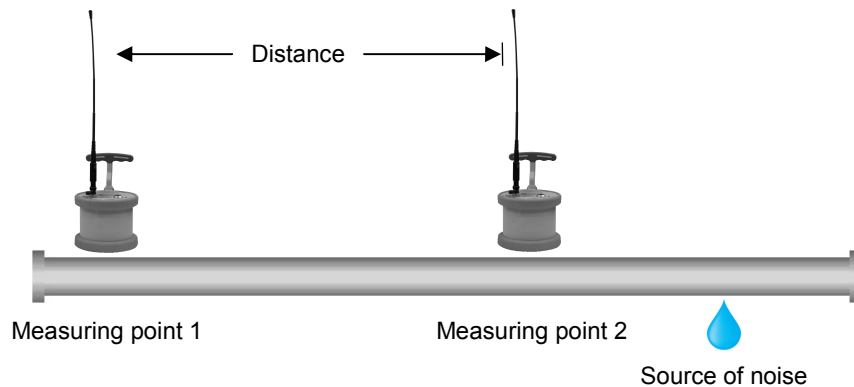

- If the source of noise is outside the measuring section, the measuring points and sound source must be arranged as shown on the following picture.



*Procedure* Proceed as follows:

Step	Description
1	Position the Power Transmitters at both measuring points, attach the sensors (Microphone / Hydrophone) to the pipe and switch the Power Transmitter on. There must be radio contact between the Power transmitters and the Correlator. (The two battery symbols in the Correlator's Start screen can be seen. These must show the battery level of the Power Transmitter. Question marks are shown if the Power transmitters are not available.)
2	Make sure the required sound source does exist.
3	In the Correlator's Start menu, use the two arrow buttons to choose the required Online measuring mode (e.g. "COR PT-3 with microphone").
4	In the main menu, tap the button  .
5	In the displayed menu, tap the <b>Tools</b> button.
6	In the displayed menu, tap the <b>Velocity measurement</b> button. <b>Result:</b> The corresponding menu opens.
7	Specify whether the source of noise is inside or outside the measuring section. Tap the appropriate button: <div style="display: flex; justify-content: space-around; margin-top: 10px;"> <div style="text-align: center;">   <b>Leak outside sensors</b> </div> <div style="text-align: center;">   <b>Leak between sensors</b> </div> </div>
8	Specify the length of the measuring section. Tap the <b>Distance between sensors</b> button.
9	Specify the distance from the first measuring point to the sound source. Tap the <b>Distance from left sensor</b> button.

Step	Description
<p>10</p>	<p>Tap the <b>OK</b> button.</p> <p><b>Result:</b> The correlation starts. The sound velocity in the pipe is calculated and displayed below the correlation curve.</p> <div data-bbox="743 427 1201 714" data-label="Figure"> </div> <p>The result is considered reliable if the following criteria are met:</p> <ul style="list-style-type: none"> <li>• The radio signal from both transmitters is good or excellent.</li> <li>• The lag value (top left of the diagram) is green and seems plausible.</li> <li>• The displayed sound velocity seems stable and plausible.</li> </ul> <p>If no reliable result is shown, you can use the <b>Cancel</b> button to terminate the measurement.</p>
<p>11</p>	<p>Tap the <b>Accept and edit pipe</b> button.</p> <p><b>Result:</b> The Pipe data menu opens.</p> <p>There, for the Material and Diameter input fields, the “Manual” option is automatically selected. The recently calculated sound velocity is accepted and shown in the corresponding field.</p> <hr/> <div data-bbox="496 1223 557 1308" data-label="Image"> </div> <p>Once the length of the pipe section is changed in this menu, the sound velocity measurement must be performed again.</p> <hr/>

Use the Back button  to return to the Start menu.

Use the button  to start a new correlation between the Power transmitters. The determined sound velocity will be used for the calculation. This applies until the pipe parameters are changed in the Pipe data menu, or the entire correlation data are reset in the system settings menu.

**12.2 Velocity measurement in Offline measurement mode**

**12.2.1 Introduction**

The **Velocity measurement** function compares the measuring values of three sensors which have recorded a shared noise. As a result, the following applications are possible:

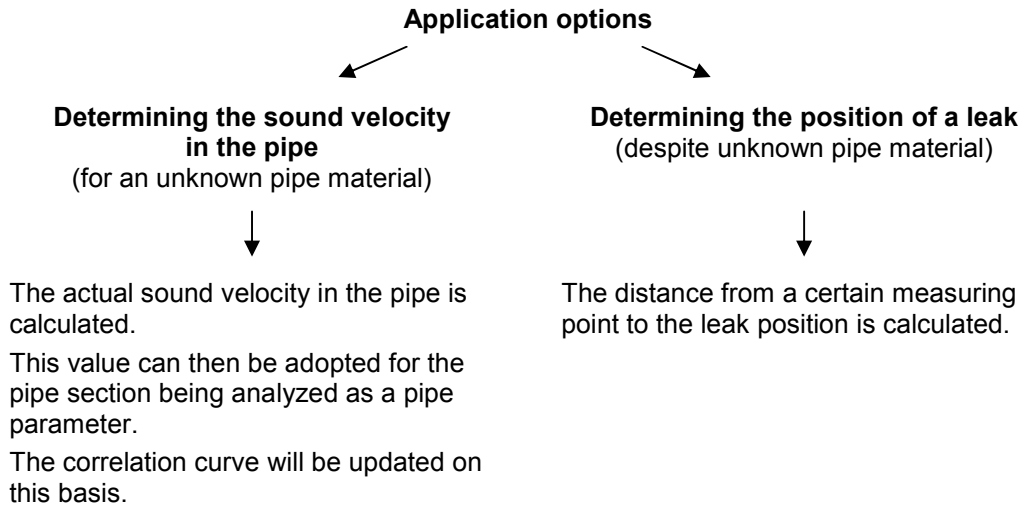

*Requirements* The following conditions must be met in order to determine sound velocity or the leak position:

- A measurement (night or instantaneous measurement) with at least 3 sensors has been performed.
- The measured data has been read and saved with the Correlator.
- Between the three considered sensors exists a clearly perceptible source of noise. (The louder the noise, the lower are the negative effects of any potential interference on the result of the sound velocity calculation).
- The lengths of the pipe sections between the measuring points must be known.
- The measuring points and sound source must be arranged as shown on the following picture.

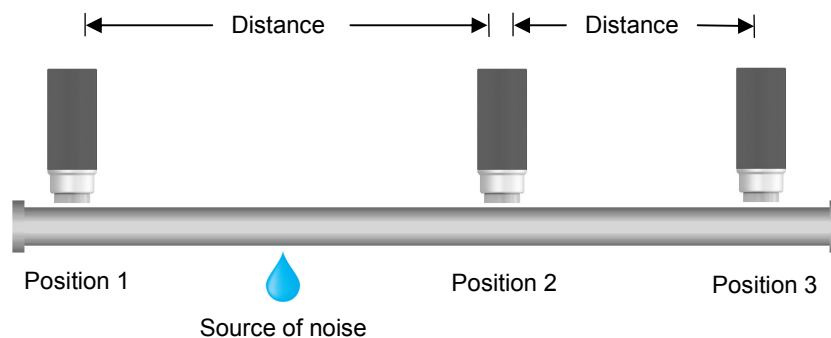

There must be one sensor „in front of“ the sound source (Position 1).  
There must be two sensors “behind” the sound source (Positions 2 and 3).

### 12.2.2 Procedure

To calculate the sound velocity in the pipe, proceed as follows:

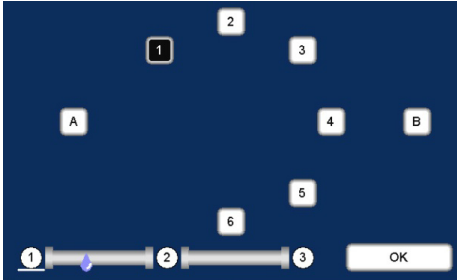
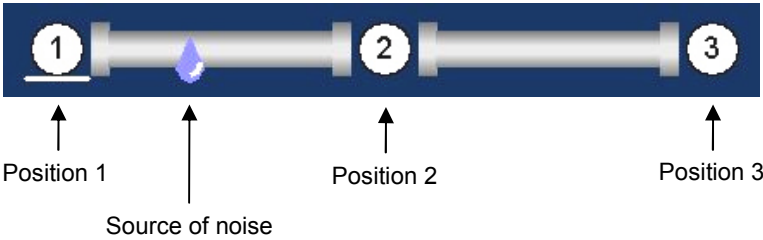
Step	Description
1	In the Correlator's Start menu, use the two arrow buttons to choose the required Offline measuring mode (e.g. "COR MS-3 with microphone").
2	In the main menu, tap the button  .
3	In the displayed menu, tap the <b>Tools</b> button.
4	In the displayed menu, tap the <b>Velocity measurement</b> button.  <b>Result:</b> The following menu opens:  <p>The square boxes represent the Multi sensors (1 to 8) or Power transmitters (A and B) used in the measurement.</p> <p>The scheme below illustrates how the sensors must be positioned in relation to the source of noise. Take care to follow this scheme when selecting the three sensors for the measurement. Otherwise the result of the calculation may be wrong.</p>  <p>The diagram shows a horizontal pipe with three sensor positions marked 1, 2, and 3. Position 1 is on the left, Position 2 is in the middle, and Position 3 is on the right. A blue flame icon representing the 'Source of noise' is located between Position 1 and Position 2, closer to Position 1. Arrows point from the labels 'Position 1', 'Position 2', and 'Position 3' to their respective sensor locations.</p>
5	Select the sensor which represents Position 1 (sensor "in front of" the sound source) by tapping the required box.  <b>Result:</b> The number of the selected sensor is shown at position 1. The white highlighting switches to position 2.
6	Select the sensor which represents Position 2 (first sensor "behind" the sound source).
7	Select the sensor which represents Position 3 (second sensor "behind" the sound source).
8	Tap the <b>OK</b> button.  <b>Result:</b> The menu for calculating the speed of sound opens.

(continued on next page)

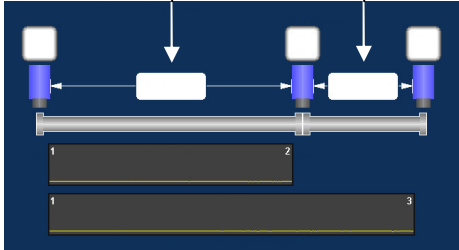
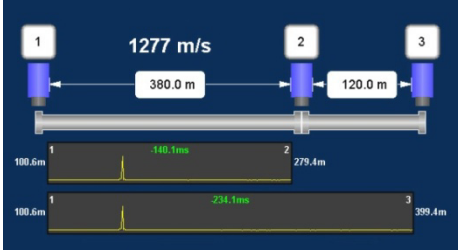
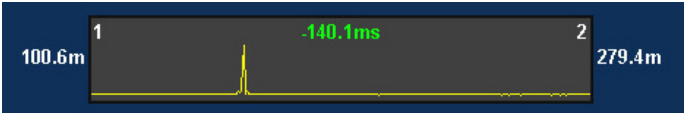
Step	Description
	<div style="text-align: center;"> <p><b>Input field:</b> Pipe section length from position 1 to 2</p> <p><b>Input field:</b> Pipe section length from position 2 to 3</p> </div> <div style="text-align: center;"> <p><b>Button:</b> Sensor No. at position 1 / 2 / 3</p>  </div>
<p><b>9</b></p>	<p>Specify the pipe length from position 1 to 2 and from position 2 to 3. For that, tap the input field between the relevant sensors. A numeric keypad is displayed. Enter the pipe section length and confirm with <b>ENTER</b>.</p> <p><b>Result:</b> The sound velocity in the pipe is calculated immediately and displayed at the top of the screen (here: 1277 m/s).</p> <div style="text-align: center;">  </div> <p>The upper diagram shows the correlation between position 1 and 2. The lower diagram shows the correlation between position 2 and 3. Next to the chart, you can read the distance from the respective measuring point to the source of noise.</p> <div style="text-align: center;">  </div> <div style="display: flex; justify-content: space-around; margin-top: 10px;"> <div style="text-align: center;"> <p>↑</p> <p>Distance from sensor No. 1 to the source of noise</p> </div> <div style="text-align: center;"> <p>↑</p> <p>Distance from sensor No. 2 to the source of noise</p> </div> </div> <hr/> <div style="border: 1px solid black; padding: 5px; margin-top: 10px;"> <p><b>i</b> You have the option to replace one of the three sensors and repeat the calculation.</p> <p>Tap the sensor to be replaced. In the next menu, tap the required new sensor, then tap <b>OK</b>. The sound velocity will be re-calculated and displayed.</p> <p>The next section offers an example.</p> </div> <hr/>
<p><b>10</b></p>	<p>Use the <b>Accept</b> button to accept the velocity value displayed as a pipe parameter for the pipe section in question. The correlation results are automatically updated in the background. The display returns to the previous menu.</p> <p>Use the <b>Cancel</b> button to cancel the velocity measurement and return to the previous menu.</p>

### 12.2.3 Notes and examples

Take care to follow this scheme at the bottom of the display area when selecting the three sensors (see step 4). Otherwise the result of the calculation may be wrong.

There must be one sensor "in front" and two sensors "behind" the source of noise. The sensors' numbers and their order on the pipe are of no importance in this process.

**Example 1:** The source of noise is located between the sensors 1 and 2.  
Entry on the Correlator: first, sensor 1 (in front of the sound source), then sensors 2 and 3 (behind the sound source).

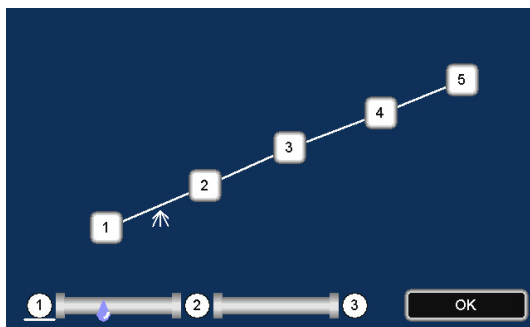

**Example 2:** The source of noise is located between the sensors 2 and 3.  
Possible entry: first, sensor 2, then sensors 3 and 4.

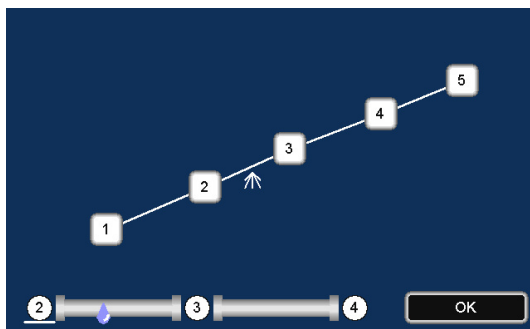

Possible entry: first, sensor 3, then sensors 2 and 1.

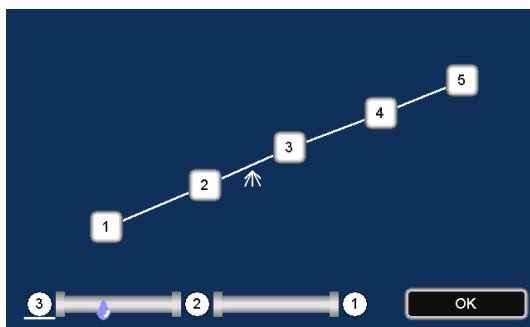





### 13 Map function

The Map function is a very clear and comfortable way to work with Offline Measurement data.

The sensors used are shown as icons. Pipelines can be drawn between these icons and the pipe parameters can be specified. In the Map menu, the existing pipe network can be reproduced on the screen.

Then, the correlation can be accessed between any sensor pairs.

*Access the Map* To access the Map menu, proceed as follows:

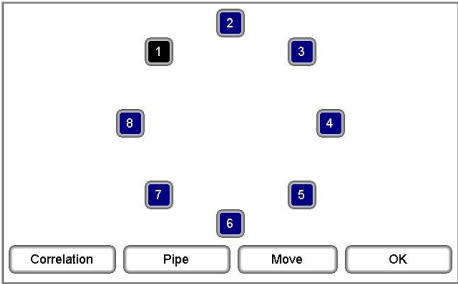

Step	Description
1	In the main menu, tap  the button .
2	In the displayed menu, tap the <b>Map</b> button. <b>Result:</b> The following menu opens:  The square boxes represent the Multi sensors (1 to 8) or Power transmitters (A + B) used in the measurement. The icons can be arranged realistically to each other by hand or, if the GPS coordinates of the measuring points have been determined and stored with the Correlator, at the touch of a button.

*Arrange sensor icons* The sensor icons can be moved and repositioned on the screen. (Only possible via touch screen, not possible via rotary encoder).

Proceed as follows:

Step	Description
1	Tap the <b>Move</b> button.
2	Tap and move the sensor icons on the screen. If GPS coordinates of the measuring points have been stored, you can use the <b>GPS</b> button to arrange the sensor icons automatically.
3	Tap on <b>Return</b> to conclude the process.

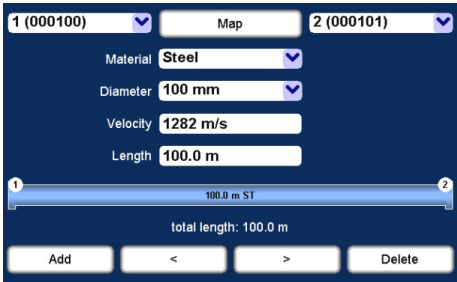
*Draw pipelines* To draw, change or delete pipelines in the map, proceed as follows:

Step	Description
1	Tap the sensor icon which represents the start point of the line.
2	Tap the sensor icon which represents the end point of the line.
3	<p>Tap the <b>Pipe</b> button.</p> <p><b>Result:</b> If there is no line between the two sensors in question so far, first the following screen appears. Tap the <b>Add</b> button.</p> 
	<p><b>Result:</b> The Pipe data menu opens.</p> 
5	<p>You can divide the displayed pipeline into individual sections if the line between the sensors is not consistently of the same material or diameter.</p> <p>Use the buttons <b>Add</b> and <b>Delete</b> to create or remove pipe sections.</p> <p>To select a section, tap directly on the relevant section in the graph or use the two arrow keys. The currently selected section is underlined white.</p> 
6	Enter the pipe data (material, diameter, length) for each pipe section.

Use the Back  button to return to the Map menu.

**Show Leak** Once the pipe net in the map is created, the correlation calculations for all sensor pairs are automatically updated in the background.

You can display the calculated leak between two sensors in the map. Proceed as follows:

Step	Description
1	Tap the first sensor.
2	Tap the second sensor.
<b>Result:</b> The leak position is marked on the map with a drop icon, provided the correlation between the two sensors in question found a leak noise.	

**Example:** The correlation of the line from sensor 5 to 2 results in a leak at the marked position.

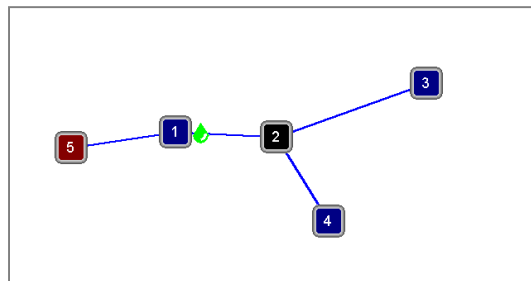

The correlation of the line from sensor 5 to 3 results in a leak at the very same position.

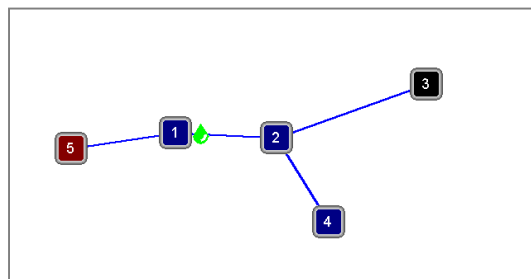

The correlation of the line from sensor 5 to 1 shows the drop icon right at sensor 1.

This indicates either that the leak is right at sensor 1 or that the leak is near sensor 1 but outside the correlated pipeline section.

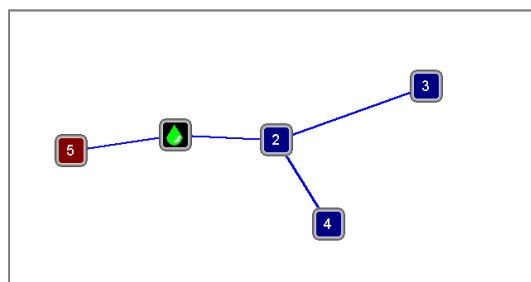

The correlation of the line from sensor 3 to 4 shows the drop icon right at sensor 2.

This indicates either that the leak is right at sensor 2 or that the leak is near sensor 2 but outside the correlated pipeline section.

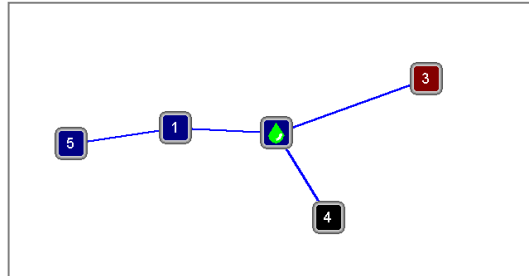

*Start correlation* To start the correlation between two sensors, proceed as follows:

Step	Description
1	Tap the first sensor (start point of the pipeline section to be correlated).
2	Tap the second sensor (end point of the pipeline section to be correlated).
3	Tap the <b>Correlation</b> button.
	<b>Result:</b> The Correlation menu opens. The correlation is displayed.

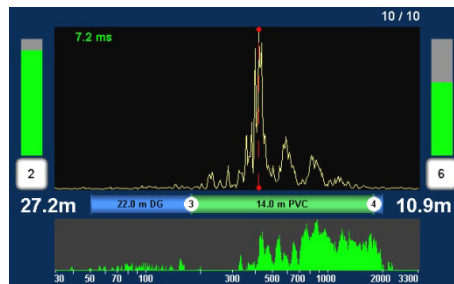

Use the various analysis tools:

- When you tap the displayed correlation curve, the **Correlation analysis** menu with the relevant tools opens.
- When you tap the displayed coherence curve, the **Frequency analysis** menu with the relevant tools opens.
- When you tap the buttons that symbolize the sensors at the measuring points (e.g. **2** and **6**), the **Audio menu** opens which can be used to listen to the stored leak noise.

For that, connect the supplied headphones to the **12 V DC /**  socket of the Correlator.

Use the Back button  to return to the previous menu.

Some settings for calculating and presenting the correlation curve can be changed in the system settings menu.

## 14 Storage / Management of correlations (History)

### 14.1 Storing a correlation

Every correlation can be saved permanently in the Correlator. This means that the measurement data of the relevant correlation is written to the Correlator's internal data base.

Saved correlations can be accessed, displayed and analyzed on the Correlator anytime. Saved correlations can also be transferred to a computer and processed there using the CorreluxView software.

If an Online correlation is not saved using the **Store** button, the corresponding measurement data is lost once the correlation menu closes. However, the entered pipe data and GPS coordinates are kept and preserved for the next correlation.

If an Offline correlation is not saved, the corresponding measurement data is lost as soon as a new Offline measurement is performed.

*Procedure* To store the displayed correlation, proceed as follows:

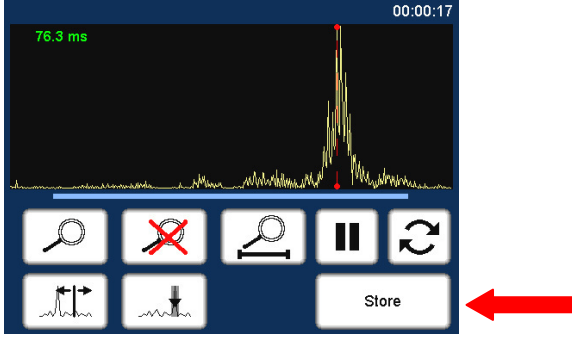
Step	Description
1	In the Correlation menu, tap on the correlation curve displayed. <b>Result:</b> The Correlation Analysis menu opens.
2	Tap the <b>Store</b> button. 
3	In the displayed menu, enter a name for this correlation. If no entry is made, a name is automatically generated. The leading 8 digits represent the date when the measurement has been performed. To confirm, tap the <b>ENTER</b> button. <b>Result:</b> The measurement data is stored in the Correlator. Subsequently, the Correlation Management menu appears on the screen. There, all stored correlations are listed.

Use the Back button  or the **ESC** pushbutton to return to the Start menu.

## 14.2 Managing stored correlations

In the **Correlation Management** menu the stored correlations are listed. There, the corresponding measurement data sets can be called up or managed.

To access the menu, proceed as follows:

Step	Description
1	In the main menu, tap the button  .
2	In the displayed menu, tap the <b>Correlation management</b> button. <b>Result:</b> The menu opens. The stored correlations are listed

### 14.2.1 Call up and display a correlation

*Call up a correlation* To call up and display a stored correlation, proceed as follows:

Step	Description
3	Select the desired correlation in the list.
4	Tap the <b>Load</b> button. <b>Result:</b> The measurement data set in question is loaded into the Correlator's memory (RAM).
5	In the main menu, tap the button  .
	<b>Result:</b> With the loaded measurement data, a correlation is performed. The Correlation menu opens and the correlation curve is displayed. The known analytical tools are available.

Use the Back button  or the **ESC** pushbutton to return to the Start menu.

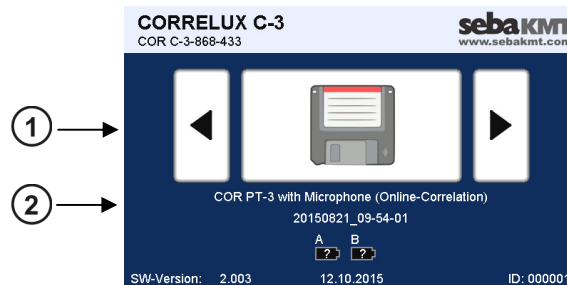

Element	Description
①	The floppy disk icon indicates that the "History" mode is active. This means that currently a stored correlation is loaded and ready to be displayed.
②	In the upper line can be read whether the loaded correlation is an Online measurement or Offline measurement. In the lower line the name of the correlation is shown.

If you tap the **large button** (floppy disk icon), the loaded correlation is displayed again.

Once you use the **arrow buttons** to set a measuring mode, the History mode is left and the loaded measurement dataset is removed from the memory.

### 14.2.2 Rename a correlation / Create a comment

The name of a stored correlation can be changed.

Furthermore, you have the chance to add a "comment" to each correlation stored which can be used to make useful annotation.

*Access the menu* In the Correlation management menu, select the desired correlation and tap the **Edit** button. The following menu opens:

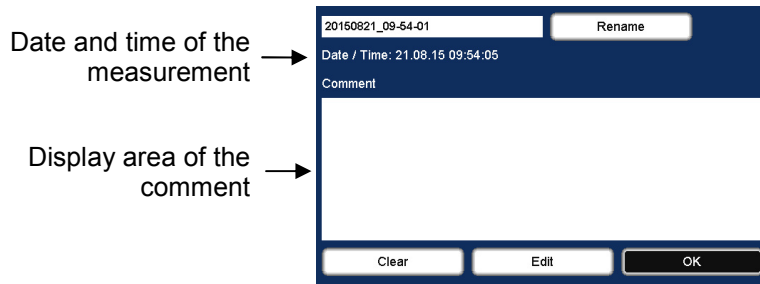

*Rename a correlation* To change the name of a stored correlation, proceed as follows:

Step	Description
1	Tap the <b>Rename</b> button.
	<b>Result:</b> A keyboard appears on the screen.
2	Enter the new name. To confirm, tap the <b>ENTER</b> button.
	<b>Result:</b> The screen returns to the previous menu.
3	Tap the <b>OK</b> button.
	<b>Result:</b> The screen returns to the Correlation management menu. The new name for the correlation in question is accepted and displayed.

*Create / edit a comment* To create a comment or to change the comment text, proceed as follows:

Step	Description
1	Tap the <b>Edit</b> button.
	<b>Result:</b> A keyboard appears on the screen
2	Enter the desired text. To confirm, tap the <b>OK</b> button.
	<b>Result:</b> The screen returns to the previous menu.
3	Tap the <b>OK</b> button.
	<b>Result:</b> The screen returns to the Correlation management menu. The new comment for the correlation in question is accepted and displayed.



Using the **Clear** button you can delete the entire comment displayed in one step. Note that this step cannot be undone.





## 15 Reset of correlation settings and data

You can delete or reset all data and settings of the most recent correlation with a single command.

This function is useful before a new measurement is prepared and performed. It ensures that the new measurement is not affected by any analysis settings from previous correlations.

*Effects* This step has the following effects:

- The Pipe data menu will be cleared, i.e. all pipe data will be deleted.
- The GPS menu will be cleared, i.e. all GPS position data will be deleted.
- The measurement values of the last correlation will be removed from the memory of the Correlator. If the correlation has not been saved, the measurement data will be lost.
- All analysis tools in the Correlation Analysis menu (e.g. zoom, suppression) will be reset to their initial state.
- The frequency filters will be reset to the broadband setting.

*Procedure* To reset all measurement settings and data, proceed as follows:

Step	Description
1	In the main menu, tap the button  .
2	In the displayed menu, tap the <b>Reset last correlation data</b> button.
3	Answer the question displayed with <b>Yes</b> .



## 16 Pinpointing

### 16.1 Introduction

After a leakage has been identified and pre-located by a correlation, the Correlator can be used to pinpoint the leak position.

*Principle of the pinpoint location* In the area of the pre-located leak position, individual measurements are performed at a number of measuring points along the probable pipe run. The noise levels recorded are displayed on the Correlator. The closer a measuring point is to the leak, the louder the recorded sound.

To determine the leak position accurately, a number of pinpointing runs are carried out in succession. With each new run, a smaller distance between the measuring points is chosen. This way, you will gradually approach the exact leak location.

*Options* The Correlux C-3 system allows two variants of how to conduct a pinpoint location:

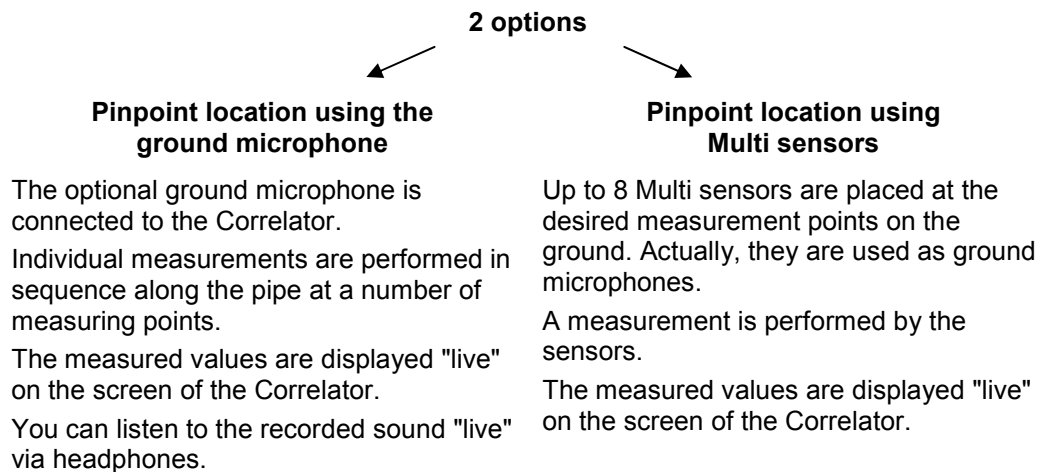

### 16.2 Pinpointing using the ground microphone







*Preparations* The following preparation work is necessary if you want to perform a pinpoint location using the optional ground microphone:

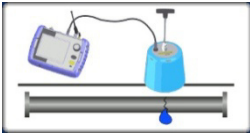
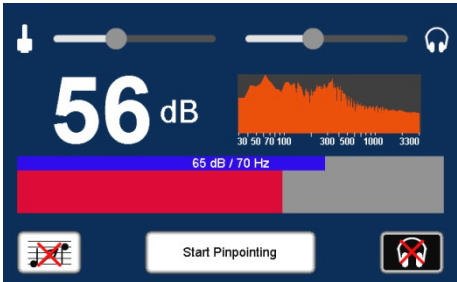

- Connect the ground microphone PAM W2 to the Correlator using the supplied VK 100 connection cable. Observe the markings on the plug and socket. You must feel the plug engage.

The Correlator's microphone socket has this icon: 

- If you want to listen to the leak noise, connect the supplied headphones to the Correlator. Use the **12 V DC** /  socket.
- Have any object/s ready which can be used during the pinpoint location to mark the position where the loudest sound will be measured.

Procedure Proceed as follows:

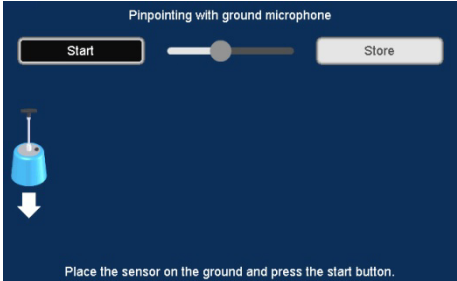
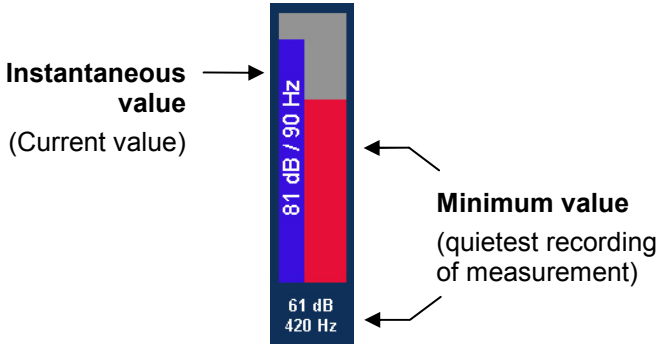
Step	Description
1	In the main menu, tap the button  .
2	In the displayed menu, tap the <b>Tools</b> button.
3	In the displayed menu, tap the <b>Pinpointing</b> button.
4	In the displayed menu, tap the upper button. 
	<p><b>Result:</b> The Audio menu for ground microphone use opens.</p> 
5	<p>Adjust the <b>microphone gain</b> for the pinpoint location using the slider at the top left of the screen.</p> <p>slide to the left ... to reduce the gain slide to the right ... to increase gain</p> <p>Prior to the first pinpointing run, it is recommended to adjusted the microphone gain in a way that the noise level bar on the screen is between 1/2 and 2/3 of it's full scale.</p> <p>This setting can be changed at any time.</p>
6	<p>Adjust the <b>frequency filter</b> for pinpointing.</p> <p>For this, tap the frequency diagram on the screen. A new menu opens. Use the buttons displayed to specify the frequency range to be regarded. The buttons are known from the Audio menu (see page 23).</p> <p> Button (on the left) to select the lower frequency limit</p> <p> Bandpass: button to suppress frequencies outside the specified range.</p> <p> Broad band: button to clear the current frequency filter and return to Broad band setting</p> <p> Bandstop: button to suppress the specified range</p> <p> Button (on the right) to select the upper frequency limit</p> <p>It is recommended to use the Broad band setting for the first pinpointing run. This setting can be adjusted at any time later.</p>

Step	Description
7	<p>In the displayed menu, tap the <b>Start Pinpointing</b> button.</p> <p><b>Result:</b> The following menu opens:</p> 
8	<p>Go to the first measuring position and put the microphone on the ground.</p>
9	<p>Tap the <b>Start</b> button.</p> <p><b>Result:</b> The measurement starts. The Current value and the Minimum value of the measurement are displayed.</p>  <p>The bar's height represents the noise level. The bar's color illustrates the frequency of the noise.</p> <p style="text-align: center;"> <span style="color: blue;">blue</span> <span style="color: purple;">purple</span> <span style="color: red;">red</span> <span style="color: orange;">orange</span> <span style="color: yellow;">yellow</span> <span style="color: yellow;">yellow</span> </p> <p style="text-align: center;">0 Hz <span style="margin-left: 150px;">3300 Hz</span></p> <p>If headphones are connected to the Correlator, you can listen to the leak noise. The sound is continuously reproduced as long as the measurement is going on. To adjust the headphone volume, use the slide control at the top of the screen.</p>
10	<p>Wait until the Minimum value has come to rest at a stable level.</p>
11	<p>Tap the <b>Store</b> button.</p> <p><b>Result:</b> The last displayed minimum value is "frozen" and displayed permanently. The headphones are muted. The microphone icon on the screen moves to the next measurement.</p> <p>If necessary, you can delete the last result using the arrow button  and repeat the measurement.</p>
12	<p>Go to the next measuring position and perform another measurement. For this, repeat the steps 6 to 9.</p> <p>Perform further measurements in the same manner.</p>

**View** Up to 10 measurement results can be displayed side by side. If more than 10 measurements are performed, always the oldest result (displayed on the very left) is dropped out of the row in favor of the new result.

Ideally, the minimum value increases with every measurement as long as you move toward the leak. The minimum value decreases again after you have passed the leak position.

The drop symbol identifies the measurement with the highest minimum value. This means that the leak noise at this measuring point is the loudest.

Example:

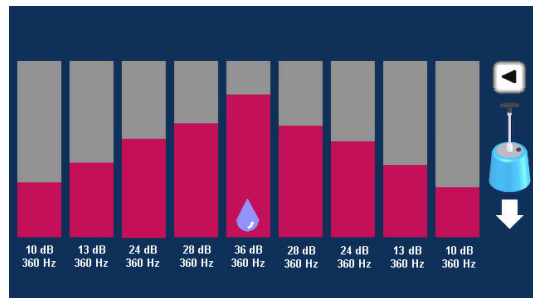

*After the first pinpointing run* After the first pinpointing run is performed, you know the approximate location of the leak. Furthermore you have an idea of the frequency spectrum and you are able to assess whether the microphone gain needs to be changed or not.

**Adjust the microphone gain**

If the height of the level bars on the screen does only change very little from measurement to measurement, you should increase the microphone gain (moving slide control in the top left of the screen to the right).

If the height of the level bars does change much too much, you should reduce the microphone gain (moving slide control in the top left of the screen to the left).

**Adjust the Frequency filter**

If the frequency values of the individual measurements share a common range, you can change the frequency filter from the Broad band setting to this frequency range (see step 6).

**Perform further pinpointing runs**

After the filter settings and microphone gain have been adjusted where necessary, perform one more pinpointing run along the pipe in the area of the pre-located leak. This time, choose a shorter distance between the measuring points.

Perform more pinpointing runs with increasingly smaller distances between the measuring points.

The leak is considered reliably localized if multiple pinpointing runs show the leak at the same position.

### 16.3 Pinpointing using Multi sensors

In the area of the pre-located leak position, up to 8 sensors are placed on the ground along the pipe. The devices record ground noise and send data to the Correlator.

Multi sensors as well as Power transmitters can be used.



**Requirements** The following requirements must be met:



- All sensors to be used must be registered in the Correlator's Multi sensor pool (also called "Offline pool" (see page 55)). This applies to both Multi sensors and Power transmitters.
- All measuring points must be within the Correlator's radio range.

**Preparations** Attach the supplied Trivet adaptors to the sensors in order to ensure safe standing and best possible contact to the ground. Thanks to their magnetic foot, the sensors simply have to be put on the trivets.

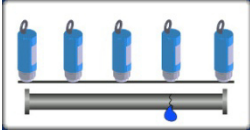
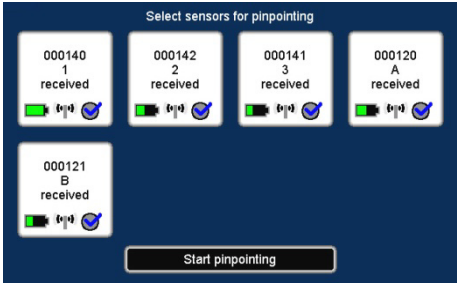

Switch the sensors on and put them on the ground, evenly spaced, along the pipe.

Procedure Proceed as follows:

Step	Description
1	In the main menu, tap the button  .
2	In the displayed menu, tap the <b>Tools</b> button.
3	In the displayed menu, tap the <b>Pinpointing</b> button.
4	In the displayed menu, tap the lower button. 
4	In the displayed menu, select the sensors that shall be used. Tap the appropriate field to enable/disable the checkbox. Only "enabled" sensors will be part of the measurement. 
5	Tap the <b>Start pinpointing</b> button. <b>Result:</b> A connection is established between the Correlator and the sensors. On the screen, the pinpointing view appears (see below in the text). The sensors start measuring. The measured values are periodically retrieved from the individual sensors and displayed by the Correlator.
6	Wait until the displayed values have come to rest at a stable level. The drop symbol identifies the measurement with the highest minimum value. This means that the leak noise at this measuring point is the loudest. 

Use the **OK** button to finish the pinpoint location.



**View** On the screen, up to 8 Multi sensor graphics are shown which represent the sensors in use. Inside the graphics, the measured values of the respective sensor are shown.

The order of the sensors on the screen does not reflect the actual position of the sensors on site. The order on the screen is based on the sensor numbers (1-8 and A/B).

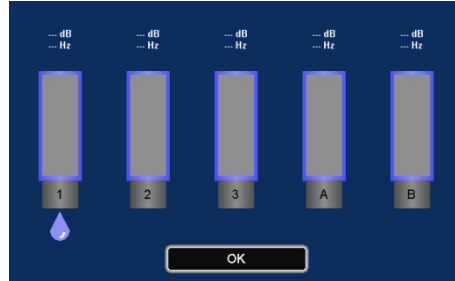

As long as the pinpoint location is in progress, in regular periods the currently measured value of each sensor is retrieved by the Correlator and displayed. In addition, the lowest measured value (Minimum value) of the current measurement is displayed for each sensor.

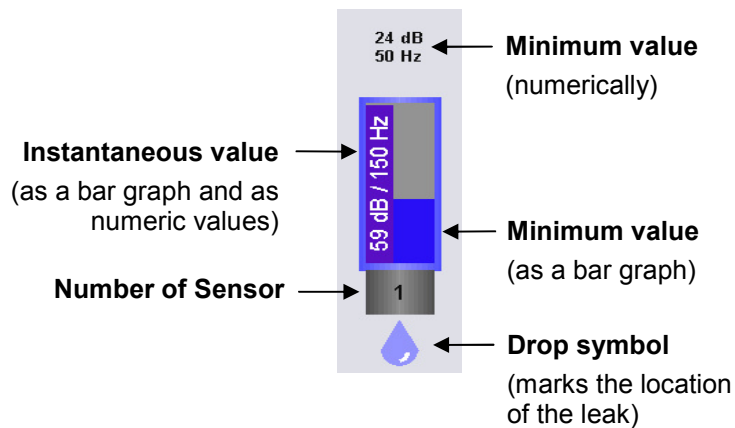

The bar's height represents the noise level.  
The bar's color illustrates the frequency of the noise.



The drop symbol identifies the sensor which has the highest minimum value. This means that the leak noise at this measuring point is the loudest.



## 17 Query the status of a device

By means of the **Read configuration** function you have the possibility to obtain information on the current configuration, the identity and the state of a Power transmitter or Multi sensor. The information is retrieved from the relevant device using the Correlator.

**Requirements** The following requirements must be met:

- The relevant sensor must be switched on.
- The sensor must be within the Correlator's radio range.

**Procedure** Proceed as follows:

Step	Description
1	If you want to read a Power transmitter, use the arrow buttons in the Start menu to go to an Online measuring mode, e.g. "COR PT-3 with microphone". If you want to read a Multi sensor, use the arrow buttons in the Start menu to go to an Offline measuring mode, e.g. "COR MS-3 with microphone".
2	In the main menu, tap the button  .
3	In the displayed menu, tap the <b>Tools</b> button.
4	In the displayed menu, tap the <b>Read configuration</b> button. <b>Result:</b> A new menu opens. The up to 8 fields displayed represent the Power transmitters and Multi sensors registered in the Correlator's sensor pool.
5	Tap on the field of the sensor which you want to read.
6	In the displayed menu, tap the <b>Read</b> button. <b>Result:</b> A connection is established between the Correlator and the device. After transfer, the data is displayed on the screen.

**View** The display shows a lot of information reflecting the status of the device. However, much of the data is only relevant for SebaKMT service technicians in case of a problem.

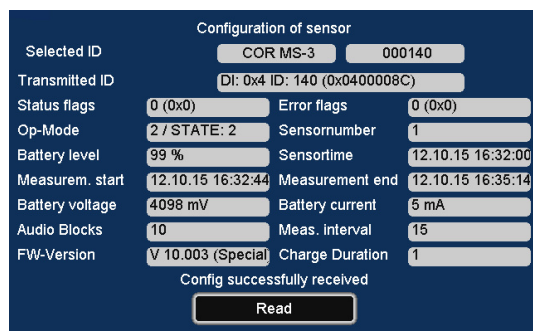

The following information may be of interest to the user:

Line	Description
<b>Selected ID</b>	Type and identification number of the sensor
<b>Sensor number</b>	Number of this sensor in the sensor pool

(continued on next page)

<b>Line</b>	<b>Description</b>
<b>Battery level</b>	Battery level of the sensor as a percentage
<b>Sensor time</b>	Current time of the sensor if it is actually programmed for an Offline measurement
<b>Measurement start</b>	Programmed start time of the Offline measurement
<b>Measurement end</b>	Programmed end time of the Offline measurement
<b>Audio blocks</b>	Number of the stored recordings (audio blocks)
<b>Meas. interval</b>	Time interval between the stored recordings
<b>FW version</b>	Currently used firmware

## 18 Firmware update

All devices of the Correlux C-3 system should be operated with the current firmware at all times.

SebaKMT makes improved versions of the firmware available in the download area of [www.sebakmt.com](http://www.sebakmt.com) on a regular basis.

### 18.1 How to update the Correlator

*Version in use* The version currently installed firmware is shown at the bottom left of the Start menu. The version can also be found in the System settings menu. There, look for the **Software version** line.

*Requirements* The following requirements must be met:

- You need a computer with access to the Internet.
- You need the supplied VK 77 connection cable.
- The battery level of the Correlator must be OK. In case of doubt it should be charged.

*Stored data* The firmware update has no impact on stored measuring data or personal settings. The data will be retained.

*Procedure* To update the Correlator, proceed as follows:

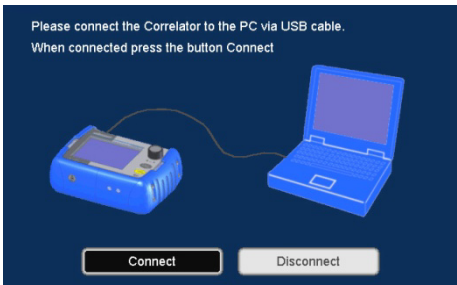
Step	Description
1	Visit the web-site <a href="http://www.sebakmt.com">www.sebakmt.com</a> . Access the Download area and look for the Correlator update-files. Download the files to your computer and unzip them.
2	<u>Correlator</u> : In the main menu, tap the button  .
3	In the displayed menu, tap <b>Firmware update / Service</b> button.
4	In the displayed menu, tap the <b>Firmware update: Correlator</b> button.  <b>Result:</b> The following menu opens:  
5	Connect the Correlator to the computer. Use the supplied connection cable. (Connect the round plug of the cable to the <b>USB / GPS</b> socket of the Correlator. Observe the markings on the plug and socket. You must feel the plug engage.)

(continued on next page)

Step	Description
6	<p>In the displayed menu, tap the <b>Connect</b> button.</p> <p><b>Result:</b> The Correlator is automatically detected by the computer as a mass storage device. The following menu opens:</p> <div data-bbox="743 427 1201 707" style="text-align: center;"> </div>
7	<p><u>Computer:</u> Copy the firmware update-files (see step 1) to the root directory of the Correlator. By that, the outdated firmware file must be overwritten there.</p>
8	<p><u>Correlator:</u> Tap the <b>OK</b> button.</p> <p><b>Result:</b> The connection to the computer is disconnected. The connection cable can be removed.</p>
9	<p>Switch the Correlator off.</p>
10	<p>Switch the Correlator on.</p> <p><b>Result:</b> The firmware update is performed. A bar on the screen shows the progress of the process.</p> <div data-bbox="483 1120 1457 1285" style="border: 1px solid black; padding: 5px;"> <div style="display: flex; align-items: center;">  <div> <p><b>NOTE</b></p> <p>The Correlator must not be operated while the update process is in progress, i.e. as long as the bar is shown on the screen. Doing so may cause irreparable damages.</p> </div> </div> </div> <p>As soon as the update process is finished the Start menu appears on the screen. At the bottom left the new firmware version is displayed. The device now is ready for use.</p>

## 18.2 How to update Power transmitters or Multi sensors

**Version in use** If you want to determine which firmware version is currently installed on a device, you can read the device's configuration (see page 111) using the Correlator. In the displayed menu, look for the **FW version** line.

**Requirements** The following requirements must be met:

- You need a computer with access to the Internet.
- You need the supplied VK 77 connection cable.
- The battery level of the devices involved must be OK.  
(Power transmitter: at least 2 green lights in the LED bar  
Multi sensor: LED shows green or yellow light)

**Procedure** First step, the relevant update-file has to be downloaded to the computer from the SebaKMT web-site and, afterwards, transferred to the Correlator.

Second step, the update-file has to be transferred from the Correlator to the relevant Power transmitter or Multi sensor, where it will be executed.

The following sections describe the steps in detail.

### 18.2.1 Work step 1: Download and store the update-file

Proceed as follows:

Step	Description
1	Visit the web-site <a href="http://www.sebakmt.com">www.sebakmt.com</a> . Access the Download area and look for the relevant update-file. Download the file to your computer and unzip it.
2	<u>Correlator</u> : In the main menu, tap the button  .
3	Connect the Correlator to the computer. Use the supplied connection cable. (Connect the round plug of the cable to the <b>USB / GPS</b> socket of the Correlator. Observe the markings on the plug and socket. You must feel the plug engage.)
4	In the displayed menu, tap the <b>Connect Correlator to PC</b> button.
5	In the displayed menu, tap the <b>Connect</b> button. <b>Result:</b> The connection is established. The message "Connected" appears on the Correlator screen. The Correlator is automatically detected by the computer as a mass storage device.
6	<u>Computer</u> : Copy the firmware update-file (see step 1) to the root directory of the Correlator. By that, the outdated firmware file must be overwritten there.
7	<u>Correlator</u> : Tap the <b>Disconnect</b> button. <b>Result:</b> The connection to the computer is disconnected. The connection cable can be removed.

18.2.2 Work step 2: Transfer and run the update-file



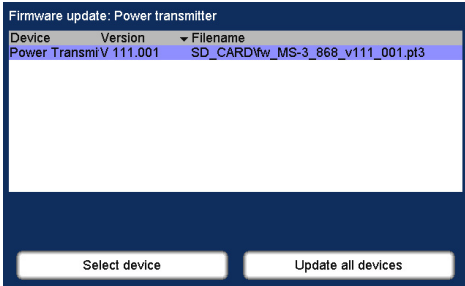

Proceed as follows:

Step	Description
1	In the Correlator main menu, tap the button  .
2	In the displayed menu, tap the <b>Firmware update / Service</b> button.
3	<p>In the displayed menu, tap the <b>Firmware update: Power transmitter</b> button if you want to update one or more Power transmitters.</p> <p>In the displayed menu, tap the <b>Firmware-Update: Multi sensor</b> button if you want to update one or more Multi sensors.</p> <p><b>Result:</b> The following menu opens:</p>  <p>In the display area, the update-file is shown which is temporarily stored in the Correlator root directory.</p> <p>If more than one file is listed, select the required one.</p> <p>If no file is displayed, there is no firmware update-file in the root directory. Perform again "Work step 1" (see page 115) in order to download the relevant file.</p>
4	<p style="text-align: center;"><b>2 options</b></p> <div style="display: flex; justify-content: space-around;"> <div style="text-align: center;"> <p>Updating one individual Power transmitter or one Multi sensor</p> <p>↓</p> <p>Tap the <b>Select device</b> button.</p> <p>↓</p> <p>(for the next steps, go to the paragraph "Updating a single device")</p> </div> <div style="text-align: center;"> <p>Updating all Power transmitters or all Multi sensors which are registered to the Correlator.</p> <p>↓</p> <p>Tap the <b>Update all devices</b> button</p> <p>↓</p> <p>(for the next steps, go to the paragraph "Updating all devices")</p> </div> </div>

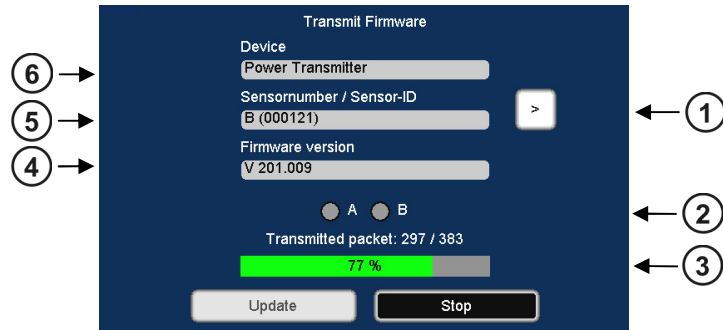

*Updating all devices* If you tapped on **Update all devices**, the following or a similar menu opens:



Element	Description
①	<b>Forward button</b>  calls the next Power transmitter or Multi sensor from the sensor pool
②	The <b>Checkboxes</b> indicate which Power transmitter ( <b>A / B</b> ) or which Multi sensors ( <b>1 - 8</b> ) are already updated. <u>Example:</u> <div style="text-align: center;">  </div> <div style="display: flex; justify-content: space-around; margin-top: 10px;"> <div style="text-align: center;">                       Power transmitter "A" is updated                 </div> <div style="text-align: center;">                       Power transmitter "B" is not yet updated                 </div> </div>
③	Progress of the data transfer.
④	Version of the new firmware
⑤	Number and ID of the selected sensor
⑥	Sensor type

Proceed as follows:

Step	Description
5	Switch on the device which is to be updated.
6	Tap the <b>Update</b> button.
<div style="display: flex; align-items: center;">  <div> <p><b>NOTE</b></p> <p>As long as the update process is in progress, no inputs or actions must be made on the devices involved and the devices must not be switched off.</p> <p>Doing so may cause irreparable damages.</p> </div> </div>	

(continued on next page)

Step	Description
	<p><b>Result:</b> The update-file is transferred to the device in question. There, the new firmware is installed and initialized. Subsequently, the device switches itself off and on again.</p> <p>A bar on the Correlator screen shows the progress of the process. Finally, the message "<b>Firmware successfully updated</b>" appears.</p>
7	<p>Tap the button  to call the next sensor from the sensor pool.</p> <p><b>Result:</b> The Number and the ID of this device are displayed.</p>
8	<p>Tap the <b>Update</b> button.</p> <p><b>Result:</b> The firmware is transferred and installed. The updated device switches itself off and on again. After all, the message "<b>Firmware successfully updated</b>" appears on the Correlator screen.</p>
9	<p>Tap the <b>OK</b> button to conclude the firmware update.</p>

Use the Back button  or the **ESC** pushbutton to return to the Start menu.

To check if a device really is operated with the new firmware read the configuration of the device in question using the Correlator (see page 111). In the displayed menu, check the **FW version** line.

*Updating a single device*

If you tapped on **Select device**, proceed as follows:

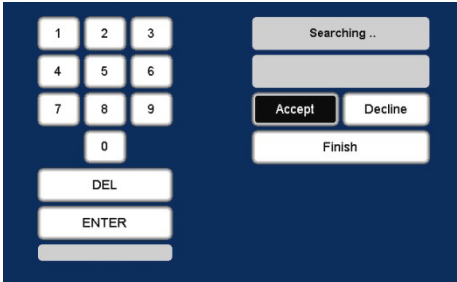
Step	Description
5	Switch on the device which is to be updated.
6	<p>Enter the ID of this device.</p> <div style="text-align: center;">  </div> <p>(Manual entry: use the numeric keypad, confirm with <b>ENTER</b> button Automatic detection: press the I/O pushbutton of the Power transmitter briefly or contact the I/O field of the Multi sensor briefly using a magnet, confirm the ID displayed with the <b>Accept</b> button)</p> <p><b>Result:</b> A new menu opens. Type and ID of the device and the new firmware version are once again displayed.</p>

Step	Description
7	<p data-bbox="480 284 762 315">Tap the <b>Update</b> button.</p> <div data-bbox="480 331 1457 533" style="border: 1px solid black; padding: 5px;">  <p data-bbox="624 344 715 376"><b>NOTE</b></p> <p data-bbox="624 389 1426 479">As long as the update process is in progress, no inputs or actions must be made on the devices involved and the devices must not be switched off.</p> <p data-bbox="624 488 1161 519">Doing so may cause irreparable damages.</p> </div> <hr/> <p data-bbox="480 591 1417 680"><b>Result:</b> The update-file is transferred to the device in question. There, the new firmware is installed and initialized. Subsequently, the device switches itself off and on again.</p> <p data-bbox="480 689 1406 748">A bar on the Correlator screen shows the progress of the process. Finally, the message "<b>Firmware successfully updated</b>" appears.</p>
8	<p data-bbox="480 763 1098 795">Tap the <b>OK</b> button to conclude the firmware update.</p>

Use the Back button  or the **ESC** pushbutton to return to the Start menu.

To check if a device really is operated with the new firmware read the configuration of the device in question using the Correlator. In the displayed menu, check the **FW version** line.



## 19 CorreluxView Software

### 19.1 User interface

The CorreluxView screen is divided into three sections - menu bar, directory tree and display area. This screen layout remains unchanged regardless of menu level.

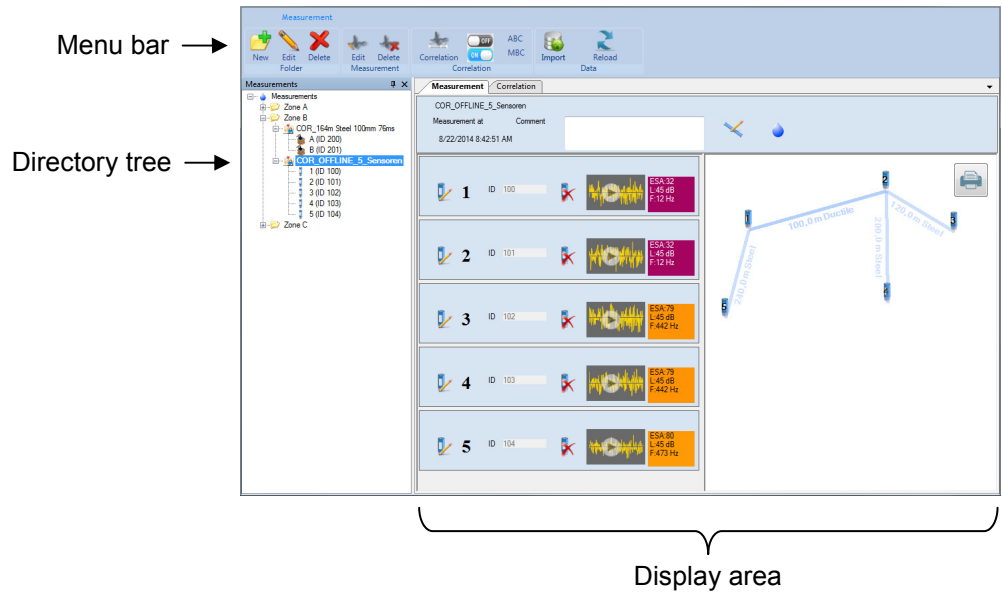

**Menu bar** The menu bar (ribbon) allows you to access any command or function. Function keys are combined appropriately into different segments. The CorreluxView symbol at the top left of the menu bar allows you to access system settings for the application.

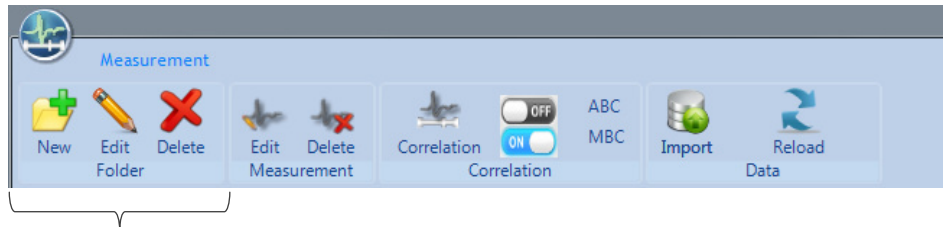

Example: 'Folder' segment containing function buttons for managing directories in the directory tree

**Directory tree** The directory structure (the so-called "directory tree") of the application's internal database is displayed to the left of the screen. Users are free to create, edit and delete directories and subdirectories in any way they wish.

*Display area* The display area is divided into the following sections:

Measurement information  
(name of correlation, time of measurement, measurement comments)

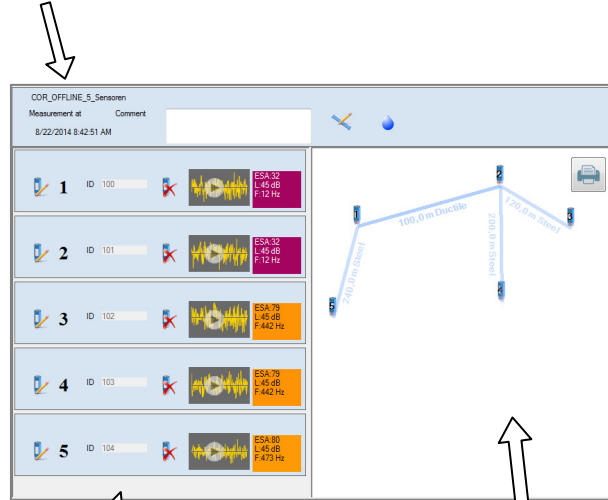

List of sensors in use

Map  
(at the very top: function keys for map management)

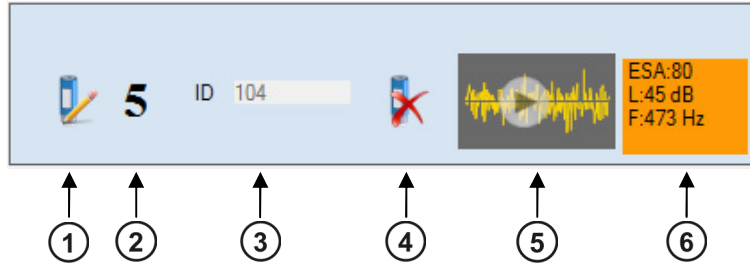

Element	Description
①	Button to <ul style="list-style-type: none"> <li>edit the GPS data for this sensor</li> <li>edit the comment text for this sensor</li> </ul>
②	Sensor number
③	Identification number for this sensor
④	Button for deleting this sensor from the list
⑤	Button for listening to the quietest recording made by this sensor
⑥	Minimum value of this sensor (ESA value, level in dB, frequency in Hz). The color of the field reflects the ESA value. <div style="text-align: center;"> <span>blue</span>  <span>yellow</span>  <span>0 Hz</span> <span style="float: right;">3300 Hz</span> </div>

## 19.2 Basic settings

You should always check basic CorreluxView software settings and adjust these if necessary before using the application.

To open the system settings menu, proceed as follows:

Step	Description
1	Click on the CorreluxView symbol  at the top left of the menu bar.
2	Click on <b>Settings</b> in the context menu.  <b>Result:</b> The system settings menu opens.

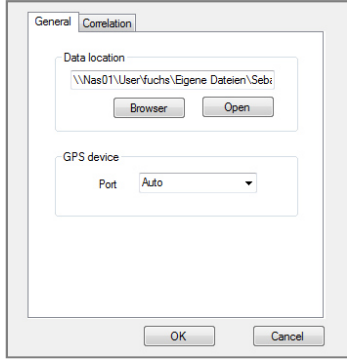

### 19.2.1 Storage location for application database

In the **Data location** segment the storage location for the CorreluxView application database is shown. This target directory was created upon initial installation of the software. All measurement data sets that are imported to the CorreluxView application by the Correlator are saved under this location.

You can use the **Open** button to open the directory.

You can use the **Browse** button to specify a new storage location. The application will display a window allowing you to navigate to the new target directory for the application database. When you are finished, click **OK** to confirm your change.

### 19.2.2 GPS receiver port

The CorreluxView application allows you to connect a GPS receiver to your computer so you can use the software to specify GPS coordinates for sensors.

Use the drop-down menu in the **GPS device** segment to select the connection port for your GPS receiver.

### 19.2.3 System of units

You can select whether **Metric** or **Imperial (Anglo-American)** units of measurement are to be used in your CorreluxView application.

Open the **Correlation** tab. Use the drop-down menu in the **Unit** segment.

### 19.2.4 Logarithmic or linear coherence display

In the Correlation menu a Coherence curve is shown. You can select whether the frequency axis for the coherence curve should rise **linearly** or **logarithmically**.

Open the **Correlation** tab. Use the drop-down menu in the **Coherence** segment.

Explanation: The frequency range of the Correlux C-3 system is from 0 to 3300 Hz. Experience shows that the frequency of leak noise ranges from 0 to 1000 Hz. The logarithmic view results in a wider display area for these lower frequencies.

Logarithmic view:

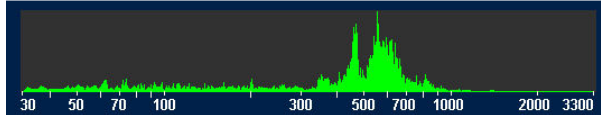

Linear view:

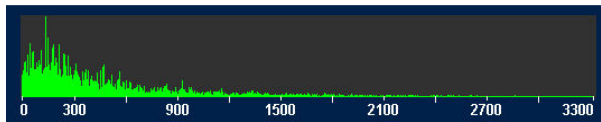

## 19.3 Creating, renaming and deleting directories

*Creating a directory* To create a new directory in the directory tree, proceed as follows:

Step	Description
1	In the directory tree, select the directory under which your new directory is to be added as a subdirectory.
2	Click on <b>New</b> in the <b>Folder</b> segment. <b>Result:</b> A new window opens.
3	Enter the name of your new directory, then click <b>OK</b> to confirm your input. <b>Result:</b> The new directory has now been created in the database and appears in the directory tree.

*Renaming a directory* You may also change the name of an existing directory. Proceed as follows:

Step	Description
1	Select the relevant directory in the directory tree.
2	Click on <b>Edit</b> in the <b>Folder</b> segment. <b>Result:</b> A window opens.
3	Enter the new name for your directory, then click on <b>OK</b> to confirm your input



*Deleting a directory* To remove a directory from the directory tree, proceed as follows:

Step	Description
1	Select the relevant directory in the directory tree.
2	Click on <b>Delete</b> in the <b>Folder</b> segment.
3	Answer <b>Yes</b> to the delete confirmation prompt.
	<b>Result:</b> The directory as well as all measurements stored under that directory are deleted from the database.

### 19.4 Importing data

To import a measurement data set from the Correlator into the CorreluxView application, proceed as follows:

Step	Description
1	Connect the Correlator to your computer. (First, establish the cable connection. Then go to the Correlator's main menu, click on the  button, then on <b>Connect Correlator to PC</b> , then on <b>Connect</b> .)
	<b>Result:</b> Your computer will automatically recognize the Correlator as a data storage device and display it under the name 'CORRELUX'.
2	Go to the CorreluxView directory tree and select the directory under which the measurement is to be added. If necessary, first create a new directory.
3	Click on <b>Import</b> in the menu bar.
	<b>Result:</b> A new window opens.
4	Navigate to the Correlator's root directory ('CORRELUX'). This directory will list a set of subdirectories that contain all measurement data sets saved.
5	Select the measurement data set you want, then click on <b>OK</b> .
	<b>Result:</b> The data import begins. The process may take a few seconds. After the data transfer is complete, the measurement will appear in the directory tree, and will also be opened for processing in the display area.

### 19.5 Editing a map

The Map section is intended to provide a realistic overview of the sensors and pipelines in the measuring area.

The sensors used are shown as icons. Pipelines can be drawn between these icons and the pipe parameters can be specified.

Provided that GPS data for the measuring points are known (i.e. the coordinates of the measuring points have been determined and saved prior to measurement), the CorreluxView application will automatically arrange the sensor icons in the map section so that they correspond to reality.

*Arrange sensor icons* To move and reposition sensor icons in the map section, proceed as follows:

Step	Description
1	The button  must be deactivated.
2	Click once on the sensor symbol you want to move. <b>Result:</b> The symbol is now highlighted and "stuck" to your mouse cursor.
3	Move your mouse cursor to the new position for the symbol, then click your mouse button again. <b>Result:</b> The sensor now occupies the new position.

*Draw pipelines* To draw in a new pipe section between two sensors, proceed as follows:

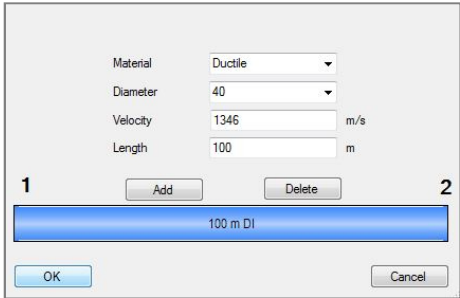
Step	Description
1	Activate the button  . It will appear highlighted.
2	In the map section, click on the first sensor (start of pipe section).
3	Move your mouse cursor to the second sensor (end of pipe section) and click on it. <b>Result:</b> A line will now connect the two sensor icons on the screen. A window opens, allowing you to enter parameters for the new pipeline.
	
4	You can use the <b>Add</b> and <b>Delete</b> buttons to divide the displayed pipeline into individual sections if the line between the sensors is not consistently of the same material or does not have a consistent diameter.
5	Enter pipe data (material, diameter, length) for each pipe section. To select a section, click directly on the relevant section in the graphic.
6	Click <b>OK</b> to confirm your input. <b>Result:</b> The window will close, and the map section will now include the new information you entered.

*Edit a section / change pipe data* Go to the map section and double-click on a given pipeline to make changes to that pipe's data or to the way you divided it into sections. The window for inputting pipe data will open.

## 19.6 Correlation

### 19.6.1 Perform and display a correlation

To display the correlation result for a measurement, proceed as follows:

Step	Description
1	Select the relevant measurement in the directory tree.
2	Click on the <b>Correlation</b> button in the menu bar.
3	<p><b>Result:</b> In the case of Online measurements, a single window will appear and display the correlation result as a curve (left graphic).</p> <p>In the case of Offline measurements, the application will provide up to 28 miniature windows (thumbnails) to display the result of the multi-correlation (right graphic).</p> <p>You will probably already be familiar with these correlation diagrams from your work with the Correlator.</p>

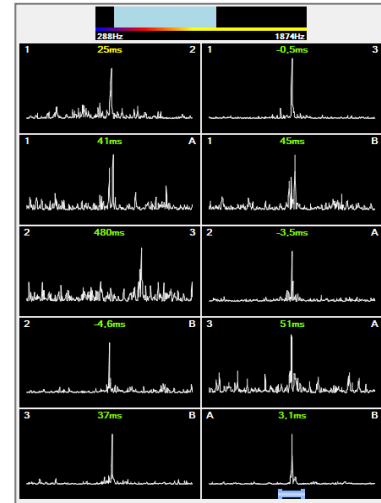
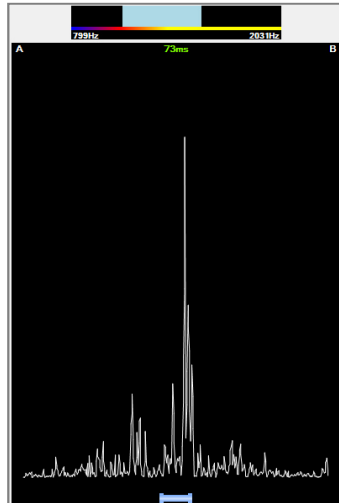

**Set frequency filters** The frequency diagram at the very top of the screen allows you to set a frequency filter and to repeat the correlation.

First, go to the graphic and click on your desired lower frequency limit, keeping your mouse key held down. Then move your mouse cursor to the right and let the key go when you've reached your desired upper frequency limit. The correlation/multi-correlation will update immediately, taking into consideration only the frequency range marked in blue.

**Change display area view** Using the **Measurement** tab at the top of the display area you can return to the view that shows the sensor list and the map. Use the **Correlation** tab to call the correlation or multicorrelation view again.

### 19.6.2 Display and select audio blocks (Offline measurements only)

*Show audio blocks* Once you click on the thumbnail of a sensor pair, 10 additional thumbnails will open at the right of the screen, showing the individual correlations of the 10 audio blocks recorded by these two sensors during measurement.

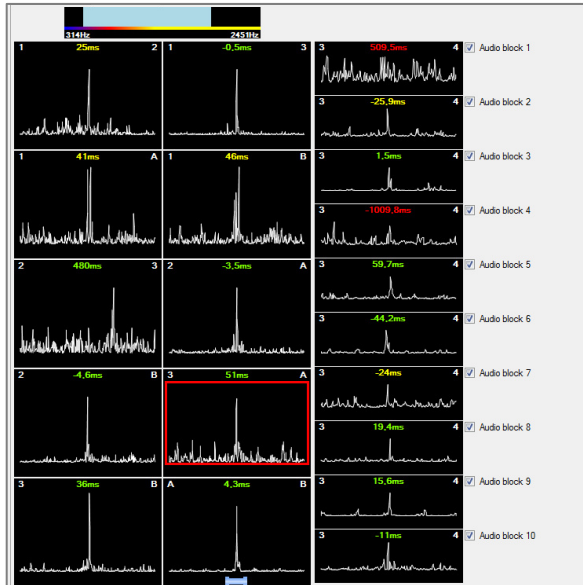

*Select audio blocks* Using the 10 checkboxes on the right, you have the chance to exclude, from the overall correlation, those individual audio block correlations which are "unusable".

To do this, just deactivate the checkbox next to the audio block in question.

The thumbnail of the sensor pair's overall correlation, highlighted by a red rectangular frame, will be updated immediately.

The "disabled" audio block will be excluded from any correlation analysis until the corresponding checkbox is ticked again.

### 19.6.3 Call up the correlation analysis menu

*Call up analysis menu* Once you click twice on a correlation displayed by CorreluxView, the analysis menu appears which can be used to more closely examine the correlation.

*Design* The menu which opens is very similar to the Correlator's Correlation menu.

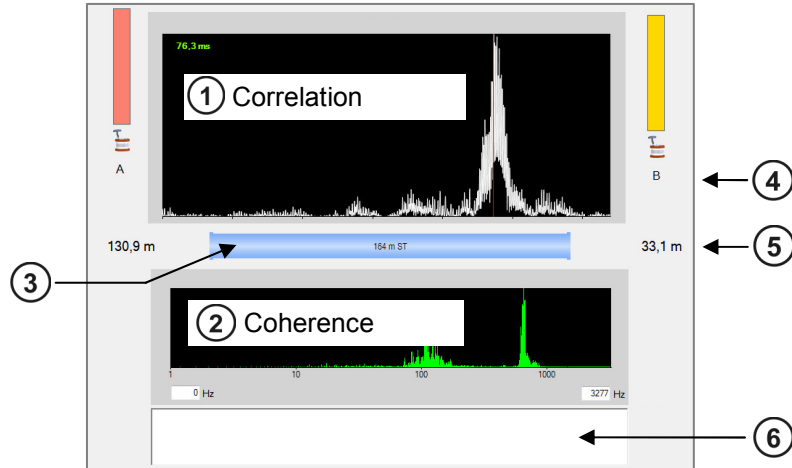

Element	Description
①	<b>Correlation curve</b> with the Lag value top left whose color indicates the quality of the correlation
②	<b>Coherence curve</b>
③	<b>Pipeline between A and B</b> Tapping the graphic opens the menu for entering pipe parameters.
④	<b>Sensor number</b>
⑤	<b>Distance from sensor to leak</b>
⑥	<b>Comment field</b> for notes on this correlation

*Tools* The buttons for analyzing correlation curve and coherence will probably also be familiar to you from your work with the Correlator.



**Zoom ...** To magnify a section of the correlation curve  
Click on the button, then select the area in the diagram on which you want to zoom.

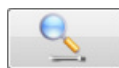

**Zoom opt. ...** Click on the button to toggle between the following two displays:

- Display of the entire correlation range
- Display of only that portion of the correlation curve which refers to the pipe section between the two measuring points



**Peak suppression ...** To hide a section of the curve from view  
Click on the button, then select the area in the diagram that you want to suppress.



**Reset ...** Sets all analysis tools as well as the correlation curve back to their initial states.

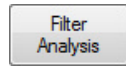

**Automatic search for filter ...** Provides 10 possible filter settings for selection

Click on the button. The application will open a window which suggests 10 possible frequency filter settings, with the most sensible highlighted.



**Bandpass ...** To delimit a frequency range

The button must first be activated. Then go to the coherence diagram and select your desired frequency range.

The correlation is updated, suppressing those frequencies which fall outside the range you selected.



**Broadband ...** Resets the frequency filter



**Bandstop ...** To suppress a frequency range.

The button must first be activated. Then go to the coherence diagram and select your desired frequency range.

The correlation is updated, hiding the selected frequency range from view.



**Print ...** Allows to print out the correlation and coherence curves that are currently displayed. Clicking on the button will open the printer dialog window.

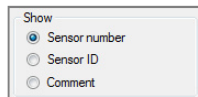

Using the radio buttons in the **Show** segment bottom right, you can select whether the two sensors (left and right of the correlation curve) are described by their Sensor number, Identification number or commentary.

### 19.6.4 Select a correlation method (Offline measurements only)

In the case of Offline measurements, one of the following two correlation methods for the multi-correlation can be chosen:

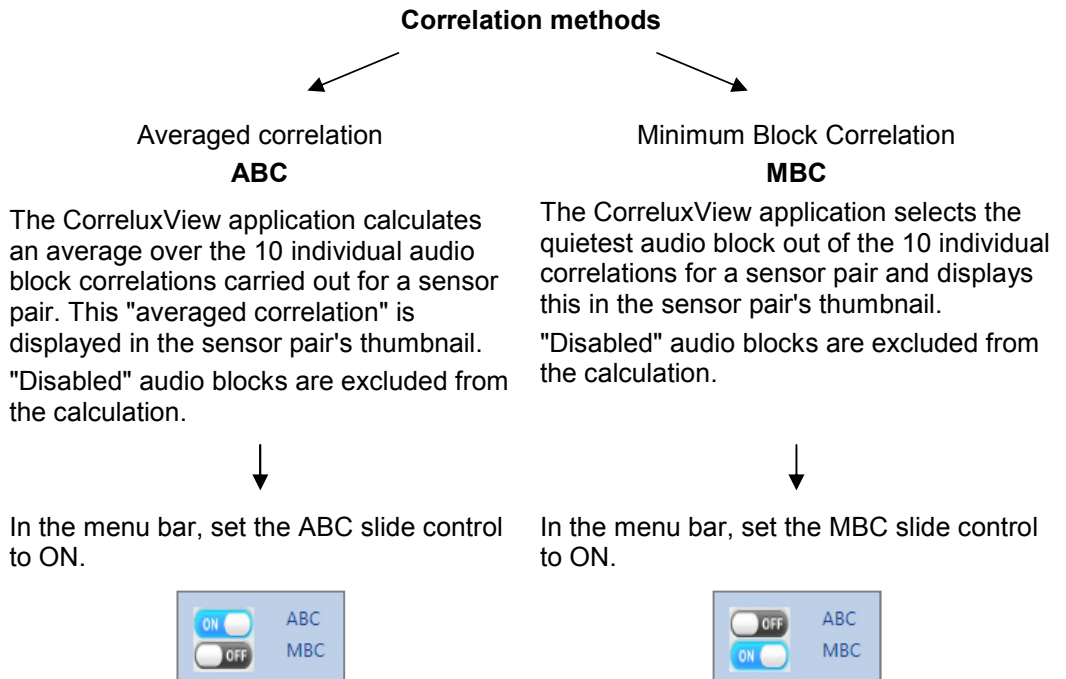



Tento symbol indikuje, že výrobek nesoucí takovéto označení nelze likvidovat společně s běžným domovním odpadem. Jelikož se jedná o produkt obchodovaný mezi podnikatelskými subjekty (B2B), nelze jej likvidovat ani ve veřejných sběrných dvorech. Pokud se potřebujete tohoto výrobku zbavit, obraťte se na organizaci specializující se na likvidaci starých elektrických spotřebičů v blízkosti svého působiště.



Dit symbool duidt aan dat het product met dit symbool niet verwijderd mag worden als gewoon huishoudelijk afval. Dit is een product voor industrieel gebruik, wat betekent dat het ook niet afgeleverd mag worden aan afvalcentra voor huishoudelijk afval. Als u dit product wilt verwijderen, gelieve dit op de juiste manier te doen en het naar een nabij gelegen organisatie te brengen gespecialiseerd in de verwijdering van oud elektrisch materiaal.



This symbol indicates that the product which is marked in this way should not be disposed of as normal household waste. As it is a B2B product, it may also not be disposed of at civic disposal centres. If you wish to dispose of this product, please do so properly by taking it to an organisation specialising in the disposal of old electrical equipment near you.



Този знак означава, че продуктът, обозначен по този начин, не трябва да се извърля като битов отпадък. Тъй като е B2B продукт, не бива да се извърля и в градски пунктове за отпадъци. Ако желаете да извърлите продукта, го занесете в пункт, специализиран в извърлянето на старо електрическо оборудване.



Dette symbol viser, at det produkt, der er markeret på denne måde, ikke må kasseres som almindeligt husholdningsaffald. Eftersom det er et B2B produkt, må det heller ikke bortskaffes på offentlige genbrugsstationer. Skal dette produkt kasseres, skal det gøres ordentligt ved at bringe det til en nærliggende organisation, der er specialiseret i at bortskaffe gammelt el-udstyr.



Sellise sümboliga tähistatud toodet ei tohi käidelda tavalise olmejäätmena. Kuna tegemist on B2B-klassi kuuluva tootega, siis ei tohi seda viia kohaliku jäätmekäitluspunkti. Kui soovite selle toote ära visata, siis viige see lähimasse vanade elektriseadmete käitlemisele spetsialiseerunud ettevõttesse.



Tällä merkinnällä ilmoitetaan, että kyseisellä merkinnällä varustettua tuotetta ei saa hävittää tavallisen kotitalousjätteen seassa. Koska kyseessä on yritysten välisen kaupan tuote, sitä ei saa myöskään viedä kuluttajien käyttöön tarkoitettuihin keräyspisteisiin. Jos haluatte hävittää tämän tuotteen, ottakaa yhteys lähimpään vanhojen sähkölaitteiden hävittämiseen erikoistuneeseen organisaatioon.



Ce symbole indique que le produit sur lequel il figure ne peut pas être éliminé comme un déchet ménager ordinaire. Comme il s'agit d'un produit B2B, il ne peut pas non plus être déposé dans une déchetterie municipale. Pour éliminer ce produit, amenez-le à l'organisation spécialisée dans l'élimination d'anciens équipements électriques la plus proche de chez vous.



Cuireann an siombail seo in iúl nár cheart an táirgeadh atá marcáilte sa tsíl seo a dhiúscairt sa chóras fuíoll teaghlaigh. Os rud é gur táirgeadh ghnó le gnó (B2B) é, ní féidir é a dhiúscairt ach oiread in ionaid dhiúscairthe phobail. Más mian leat an táirgeadh seo a dhiúscairt, déan é a thógáil ag eagraíocht gar duit a sainfheidhmiú in ndiúscairt sean-fhearas leictrigh.



Dieses Symbol zeigt an, dass das damit gekennzeichnete Produkt nicht als normaler Haushaltsabfall entsorgt werden soll. Da es sich um ein B2B-Gerät handelt, darf es auch nicht bei kommunalen Wertstoffhöfen abgegeben werden. Wenn Sie dieses Gerät entsorgen möchten, bringen Sie es bitte sachgemäß zu einem Entsorger für Elektroaltgeräte in Ihrer Nähe.



Αυτό το σύμβολο υποδεικνύει ότι το προϊόν που φέρει τη σήμανση αυτή δεν πρέπει να απορρίπτεται μαζί με τα οικιακά απορρίμματα. Καθώς πρόκειται για προϊόν B2B, δεν πρέπει να απορρίπτεται σε δημοτικά σημεία απόρριψης. Εάν θέλετε να απορρίψετε το προϊόν αυτό, παρακαλούμε όπως να το παραδώσετε σε μία υπηρεσία συλλογής ηλεκτρικού εξοπλισμού της περιοχής σας.



Ez a jelzés azt jelenti, hogy az ilyen jelzéssel ellátott terméket tilos a háztartási hulladékokkal együtt kidobni. Mivel ez vállalati felhasználású termék, tilos a lakosság számára fenntartott hulladékgyűjtőbe dobni. Ha a terméket ki szeretné dobni, akkor vigye azt el a lakóhelyéhez közel működő, elhasznált elektromos berendezések begyűjtésével foglalkozó hulladékkezelő központhoz.



Questo simbolo indica che il prodotto non deve essere smaltito come un normale rifiuto domestico. In quanto prodotto B2B, può anche non essere smaltito in centri di smaltimento cittadino. Se si desidera smaltire il prodotto, consegnarlo a un organismo specializzato in smaltimento di apparecchiature elettriche vecchie.



Št zíme noráda, ka izstrādājumu, uz kura tā atrodas, nedrīkst izmest kopā ar parastiem mājstaiņiem atkritumiem. Tā kā tas ir izstrādājums, ko cits citam pārdod un lieto tikai uzņēmumi, tad to nedrīkst arī izmest atkritumos tādās izgāztuvēs un atkritumu savāktuvēs, kas paredzētas vietējiem iedzīvotājiem. Ja būs vajadzīgs šo izstrādājumu izmest atkritumos, tad rīkojieties pēc noteikumiem un nogādājiet to tuvākajā vietā, kur īpaši nodarbojas ar vecu elektrisku ierīču savākšanu.



Šis simbolis rodo, kad juo paženklinto gaminio negalima išmesti kaip paprastų buitinių atliekų. Kadangi tai B2B (verslas verslui) produktas, jo negalima atiduoti ir buitinių atliekų tvarkymo įmonėms. Jei norite išmesti šį gaminį, atlikite tai tinkamai, atiduodami jį arti jūsų esančiai specializuotai senos elektrinės įrangos utilizavimo organizacijai.



Dan is-simbolu jindika li l-prodott li huwa mmarkat b'dan il-mod m'ghandux jintrema bhal skart normali tad-djar. Minhabba li huwa prodott B2B , ma jistax jintrema wkoll f'centri civici ghar-rimi ta' l-iskart. Jekk tkun tixtieq tarmi dan il-prodott, jekk joghgbok ghamel dan kif suppost billi tieghu ghand organizzazzjoni fil-qrib li tispelializza fir-rimi ta' taghmir qadim ta' l-eletriku.



Dette symbolet indikerer at produktet som er merket på denne måten ikke skal kastes som vanlig husholdningsavfall. Siden dette er et bedriftsprodukt, kan det heller ikke kastes ved en vanlig miljøstasjon. Hvis du ønsker å kaste dette produktet, er den riktige måten å gi det til en organisasjon i nærheten som spesialiserer seg på kassering av gammelt elektrisk utstyr.



Ten symbol oznacza, że produktu nim opatrzonego nie należy usuwać z typowymi odpadami z gospodarstwa domowego. Jest to produkt typu B2B, nie należy go więc przekazywać na komunalne składowiska odpadów. Aby we właściwy sposób usunąć ten produkt, należy przekazać go do najbliższej placówki specjalizującej się w usuwaniu starych urządzeń elektrycznych.



Este símbolo indica que o produto com esta marcação não deve ser deixado fora juntamente com o lixo doméstico normal. Como se trata de um produto B2B, também não pode ser deixado fora em centros cívicos de recolha de lixo. Se quiser desfazer-se deste produto, faça-o correctamente entregando-o a uma organização especializada na eliminação de equipamento eléctrico antigo, próxima de si.



Acest simbol indică faptul că produsul marcat în acest fel nu trebuie aruncat ca și un gunoi menajer obișnuit. Deoarece acesta este un produs B2B, el nu trebuie aruncat nici la centrele de colectare urbane. Dacă vreți să aruncați acest produs, vă rugăm s-o faceți într-un mod adecvat, ducând-ul la cea mai apropiată firmă specializată în colectarea echipamentelor electrice uzate.



Tento symbol znamená, že takto označený výrobek sa nesmie likvidovať ako bežný komunálny odpad. Keďže sa jedná o výrobok triedy B2B, nesmie sa likvidovať ani na mestských skládkach odpadu. Ak chcete tento výrobok likvidovať, odnesť ho do najbližšej organizácie, ktorá sa špecializuje na likvidáciu starých elektrických zariadení.



Ta simbol pomeni, da izdelka, ki je z njim označen, ne smete zavreči kot običajne gospodinjске odpadke. Ker je to izdelek, namenjen za druge proizvajalce, ga ni dovoljeno odlagati v centrih za civilno odlaganje odpadkov. Če želite izdelek zavreči, prosimo, da to storite v skladu s predpisi, tako da ga odpeljete v bližnjo organizacijo, ki je specializirana za odlaganje stare električne opreme.



Este símbolo indica que el producto así señalado no debe desecharse como los residuos domésticos normales. Dado que es un producto de consumo profesional, tampoco debe llevarse a centros de recogida selectiva municipales. Si desea desechar este producto, hágalo debidamente acudiendo a una organización de su zona que esté especializada en el tratamiento de residuos de aparatos eléctricos usados.



Den här symbolen indikerar att produkten inte får blandas med normalt hushållsavfall då den är förbrukad. Eftersom produkten är en så kallad B2B-produkt är den inte avsedd för privata konsumenter, den får således inte avfallshanteras på allmänna miljö- eller återvinningsstationer då den är förbrukad. Om ni vill avfallshandla den här produkten på rätt sätt, ska ni lämna den till myndighet eller företag, specialiserad på avfallshandling av förbrukad elektrisk utrustning i ert närområde.