

SMP-CR-16

Collapsible Take-Up Reel with Floor Stand

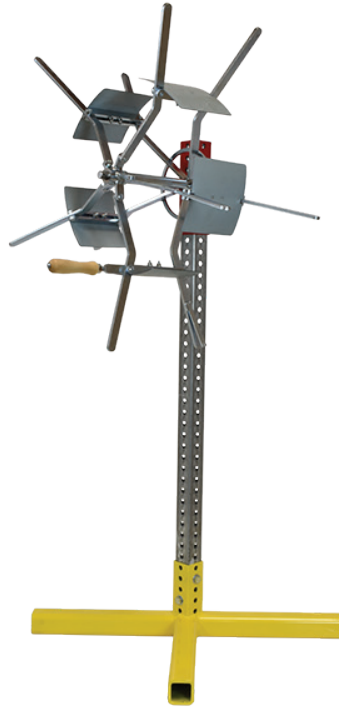

Ideal for re-coiling materials stored on a reel rack system, the SMP-CR-16 height adjustable coiler forms a 15" inside diameter round coil which can be tied before collapsing. Unlike most other coilers on the market, the SMP-CR-16 offers a smoother collapse that can be performed single-handedly with ease by any operator. When collapsed, the formed coil off-loads to the front of the machine. This collapsible coiler features a heavy-duty welded steel base with telescopic upright section.

Features:

- Sold as one (1) SMP-CR-16 system (wire sold separately)
- Maximum weight capacity: 100 lbs. of coiled material
- Outside dimensions: 44" H x 28" W x 28" D
- Product weight: 61 lbs.
- Coil inside diameter: 15"
- Powder coated base and coiler mount
- Frames constructed of 10-gauge steel
- Coil off-loads to the front of the machine
- Coil can be tied/secured prior to collapsing
- Telescopic uprights for easy height adjustment
- Ergonomic wooden handle
- Made in the USA

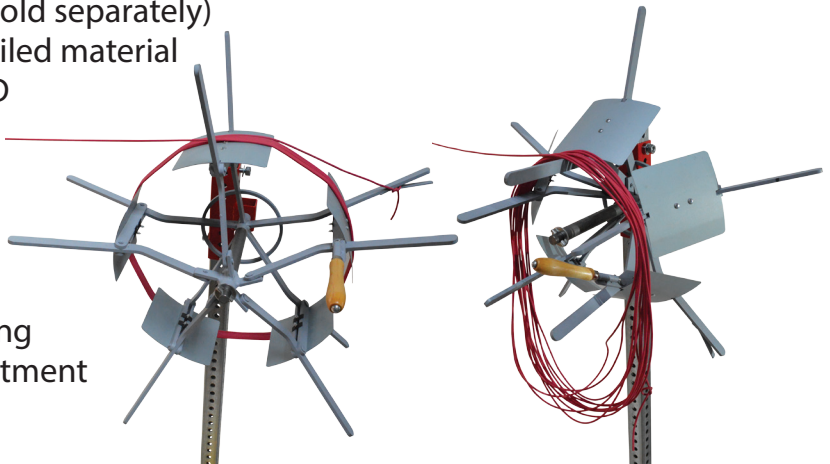

P.O. Box 12017 Marina del Rey, CA 90292
Phone: 310-822-6290 Fax: 310-306-9343
Email: info@spoolmaster.com
Visit us online at www.spoolmaster.com



SMP-CR-16

Collapsible Take-Up Reel with Floor Stand

Dimensions:

Height: 44" (111.8 cm)
Width: 28" (71.1 cm)
Depth: 28" (71.1 cm)
Weight: 61 lbs (27.7 kg)

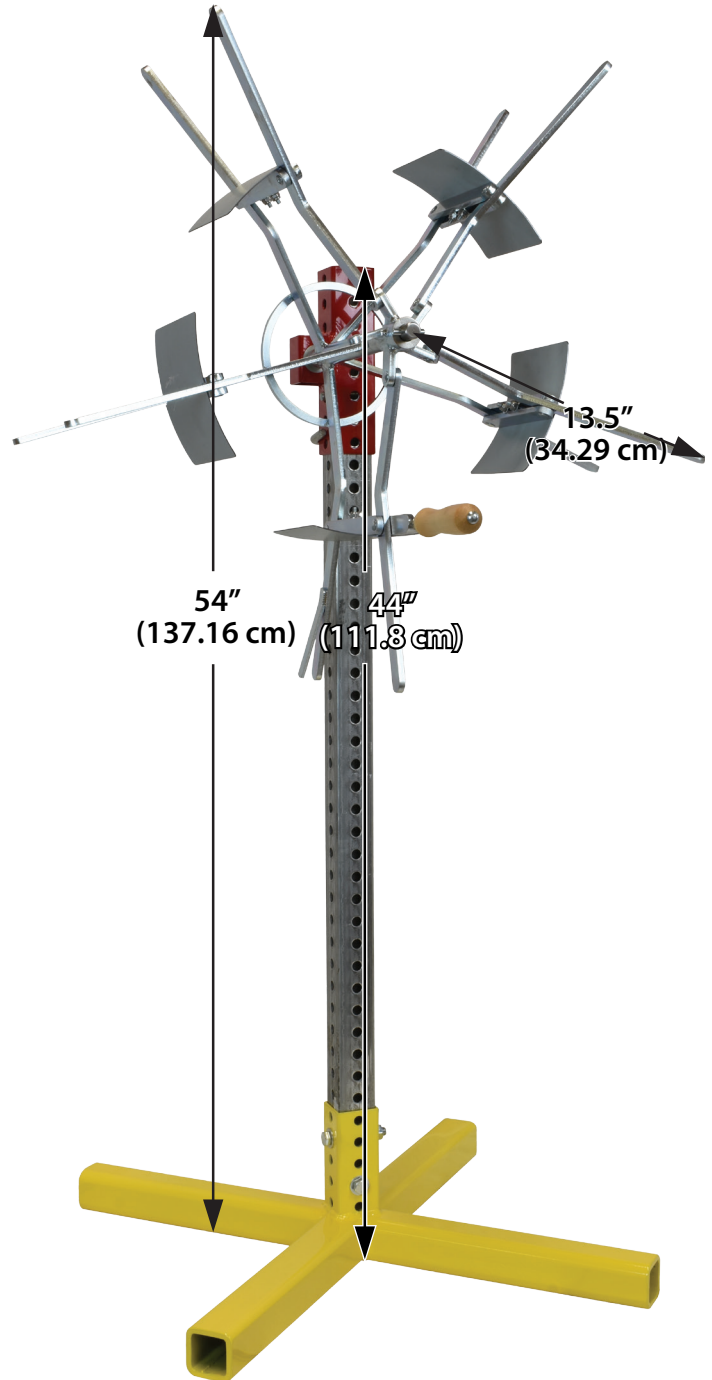
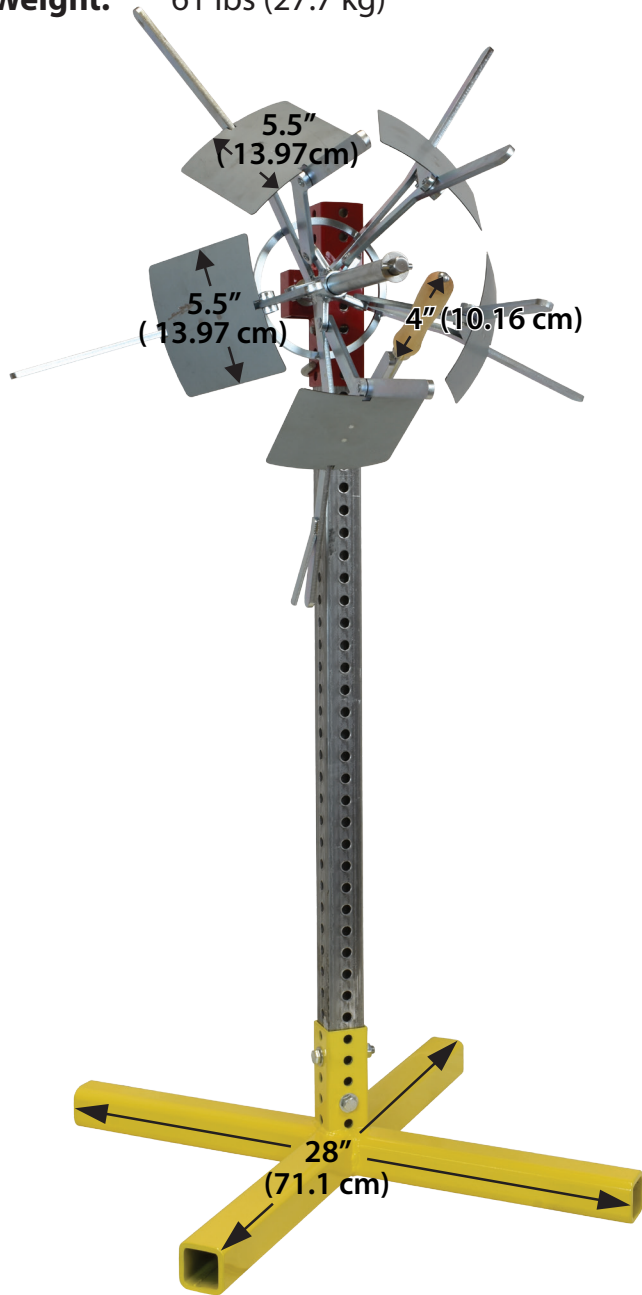

P.O. Box 12017 Marina del Rey, CA 90292
Phone: 310-822-6290 Fax: 310-306-9343
Email: info@spoolmaster.com
Visit us online at www.spoolmaster.com

